

# WINCORE™

## WINDOWS & DOORS

250 Staunton Turnpike, Parkersburg, WV 26104

### 400 SERIES

## Vinyl Horizontal Sliding Window

### w/ Nailing Fin

### "NON-IMPACT"

#### GENERAL NOTES

1. This product has been evaluated and is in compliance with the 2010 Florida Building Code (FBC) structural requirements excluding the "High Velocity Hurricane Zone" (HVHZ).
2. Product anchors shall be as listed and spaced as shown on details. Anchor embedment to base material shall be beyond wall dressing or stucco.
3. When used in areas requiring wind borne debris protection this product is required to be protected with an impact resistant covering that complies with Section 1609.1.2 of the FBC.
4. For 2x stud framing construction, anchoring of these units shall be the same as that shown for 2x buck masonry construction. Increase anchor length to account for exterior sheathing.
5. Site conditions that deviate from the details of this drawing require further engineering analysis by a licensed engineer or registered architect.

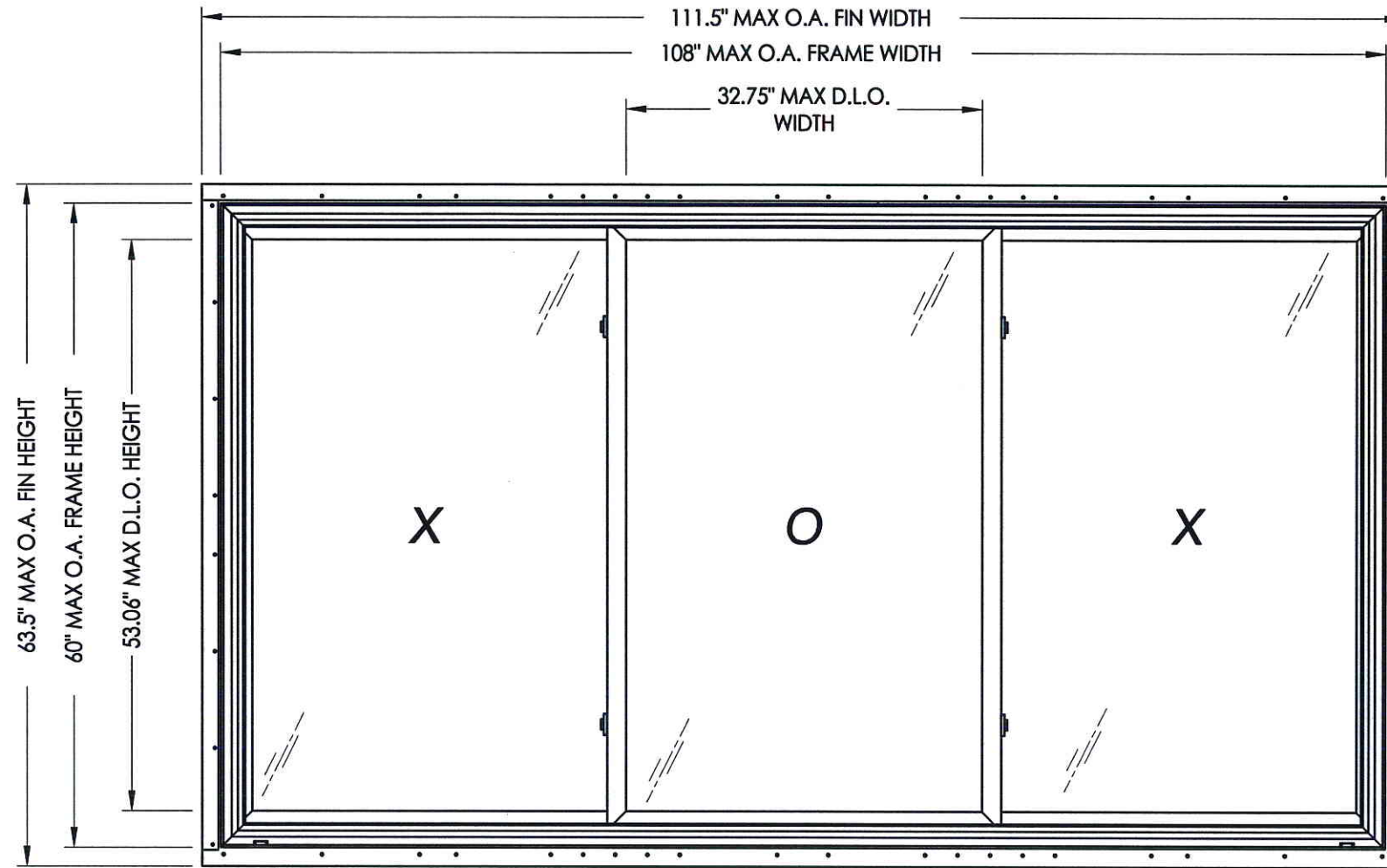

TABLE OF CONTENTS	
SHEET#	DESCRIPTION
1	Typical elevations, design pressures and general notes
2	Horizontal and vertical cross sections
3	Buck and frame anchoring
4	Bill of materials, components & glazing details

MAX. FIN DIMENSION	MAX. FRAME DIMENSION	MAX. D.L.O. DIMENSION	GLASS TYPE	DESIGN PRESSURE (PSF)	
				POSITIVE	NEGATIVE
111.5" X 63.5"	108.0" X 60.0"	32.75" X 53.06"	G1	+25.0	-25.0

Documents Prepared By:

**RW** BUILDING CONSULTANTS, INC.  
P.O. Box 230 Valrico FL 33595  
Phone No.: 813.659.9197  
Florida Board of Professional Engineers  
Certificate Of Authorization No. 9813  
10-24-13  
Lyndon F. Schmidt, P.E. No. 43409

PRODUCT: 400 SERIES  
1/3-1/3-1/3  
PART OR ASSEMBLY:  
TYPICAL ELEVATION, DESIGN PRESSURES & GENERAL NOTES

NO.	DATE	BY	REVISIONS

DATE: 10/4/13  
SCALE: N.T.S.  
DWG. BY: JK  
CHK. BY: LFS  
DRAWING NO.: FL-16092.14  
SHEET 1 OF 4

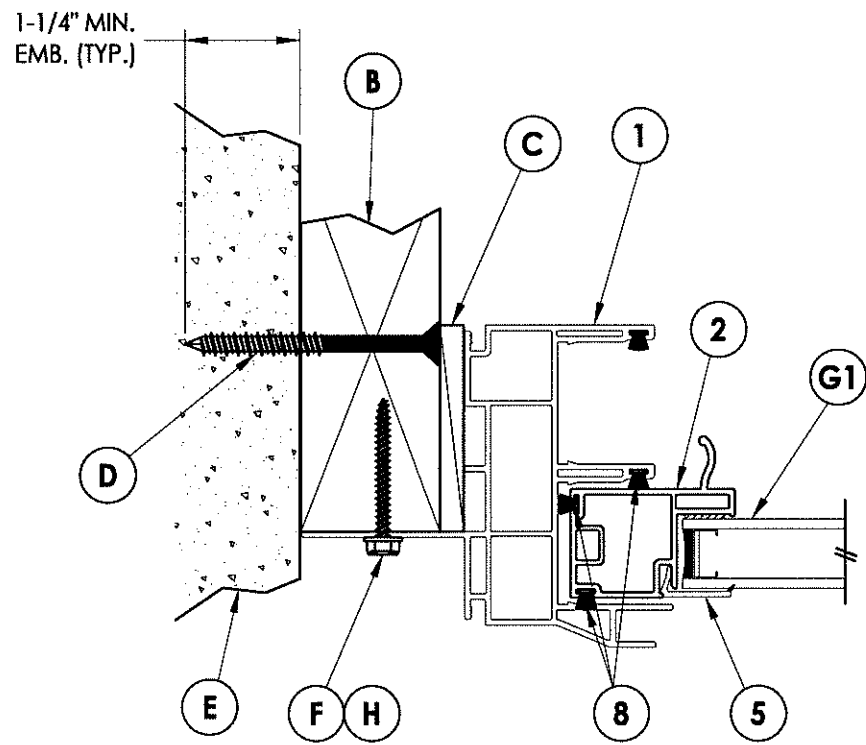
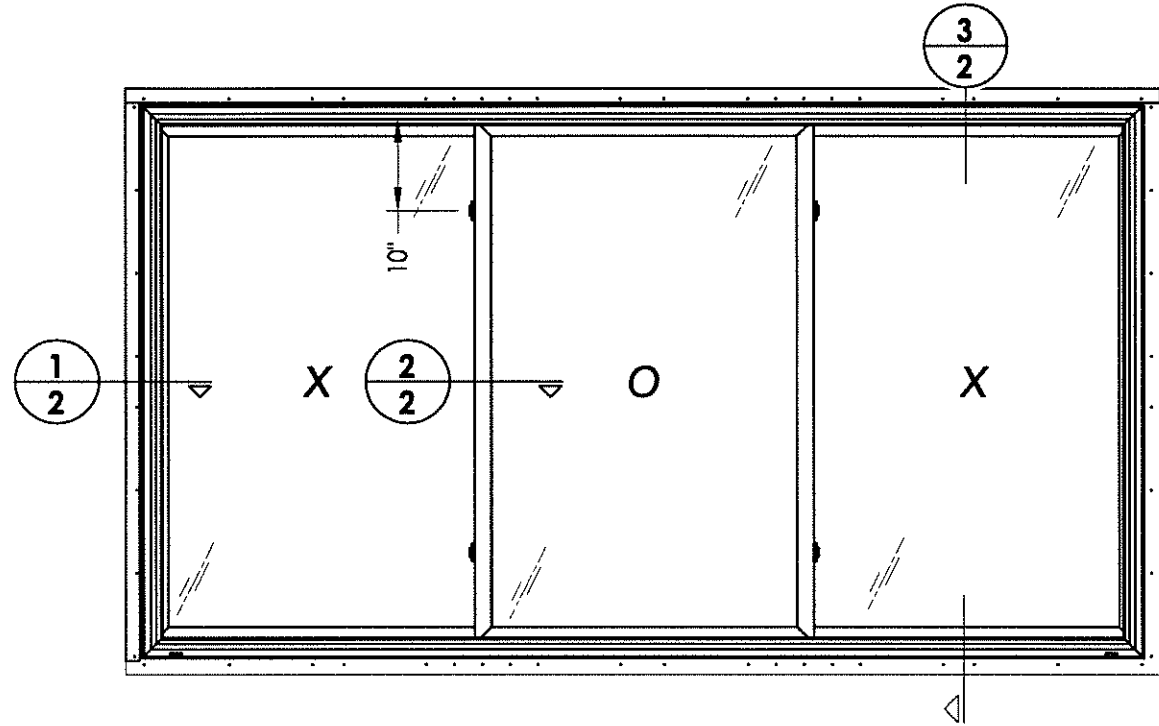

**1** HORIZONTAL CROSS SECTION  
**2**

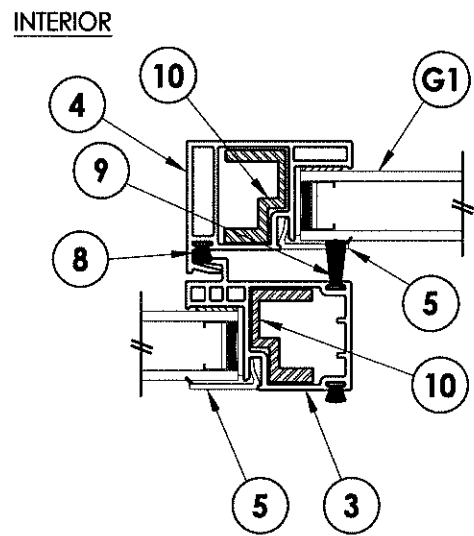

EXTERIOR

**2** HORIZONTAL CROSS SECTION  
**2**

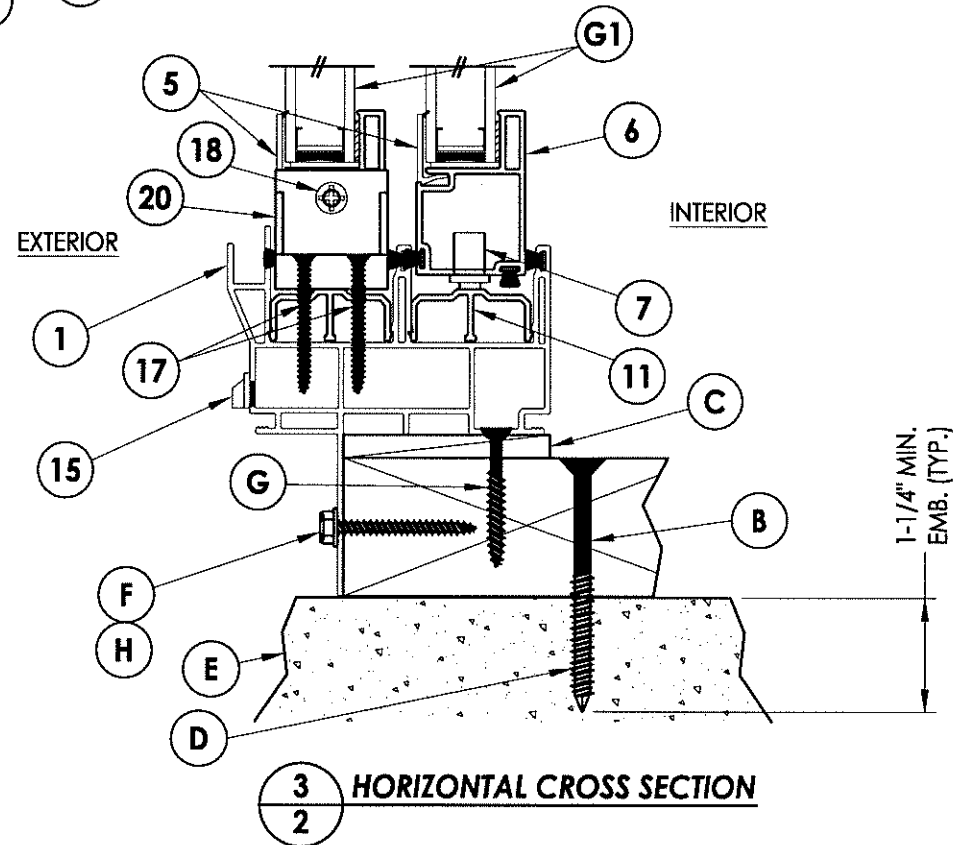
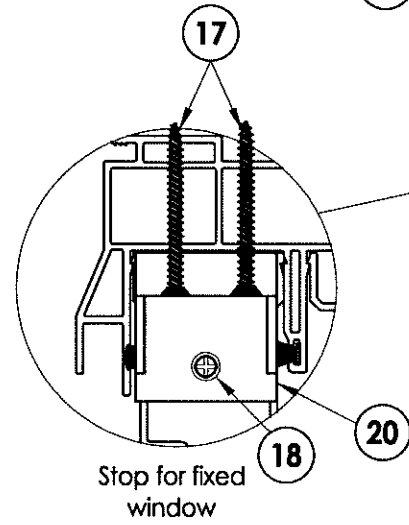

**3** HORIZONTAL CROSS SECTION  
**2**

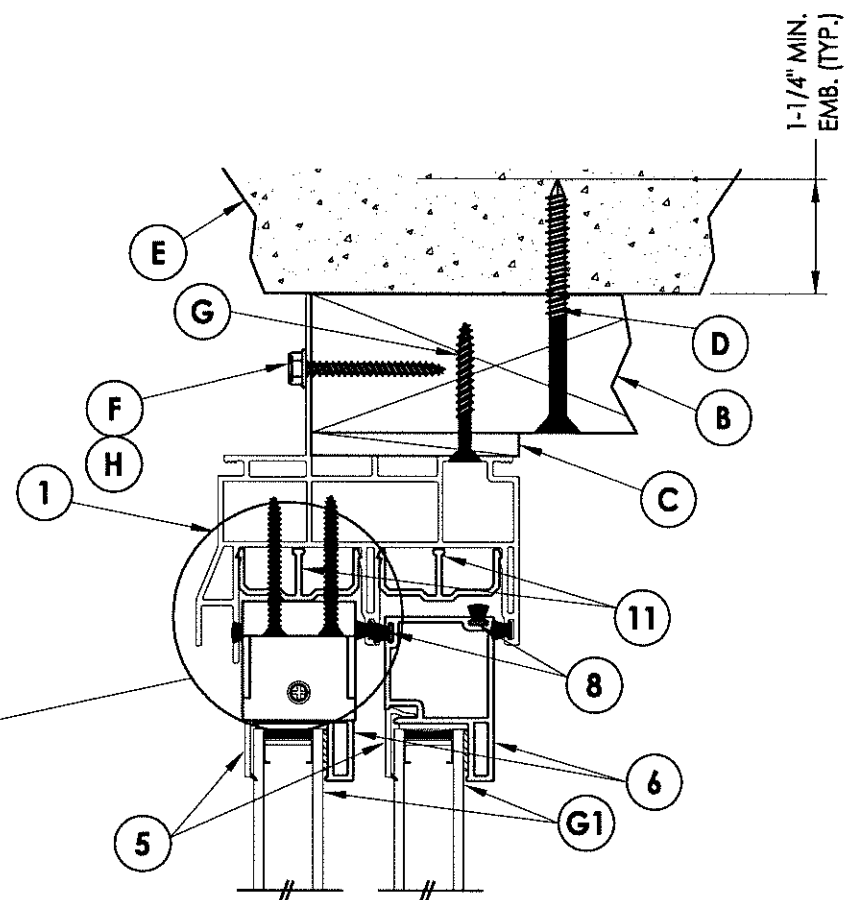

1-1/4" MIN.  
EMB. (TYP.)

Documents Prepared By:

**RW** BUILDING CONSULTANTS, INC.  
P.O. Box 230 Valrico FL, 33595  
Phone No.: 813.659.9197  
Florida Board of Professional Engineers  
Certificate Of Authorization No. 9813  
10-24-13  
Lyndon F. Schmidt, P.E. No. 43409

PRODUCT: 400 SERIES  
1/3-1/3-1/3

PART OR ASSEMBLY:  
HORIZONTAL AND VERTICAL  
CROSS SECTIONS

NO.	DATE	BY	REVISIONS

DATE: 10/4/13  
SCALE: N.T.S.  
DWG. BY: JK  
CHK. BY: LFS  
DRAWING NO.: FL-16092.14

SHEET 2 OF 4

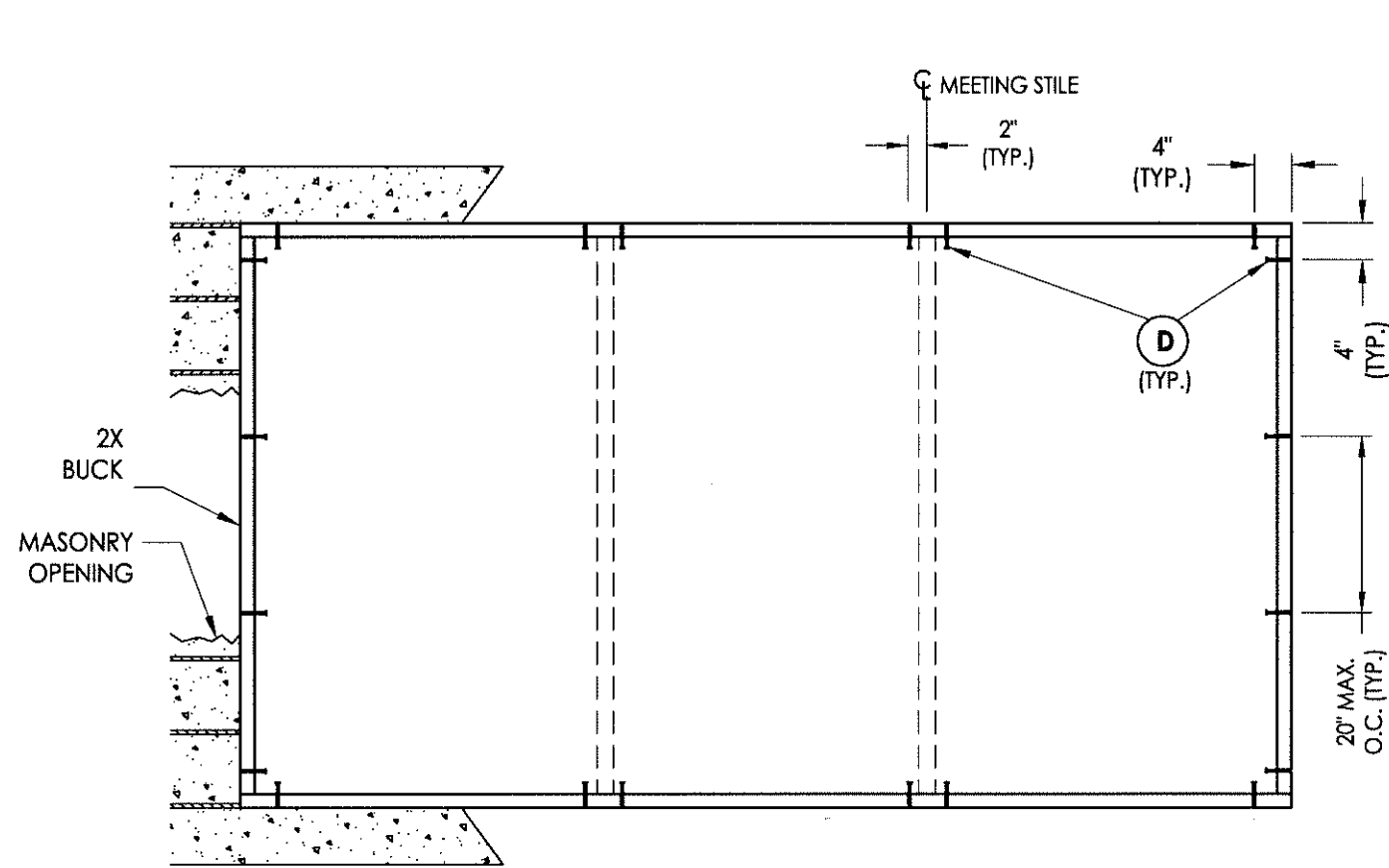

**BUCK ANCHORING**

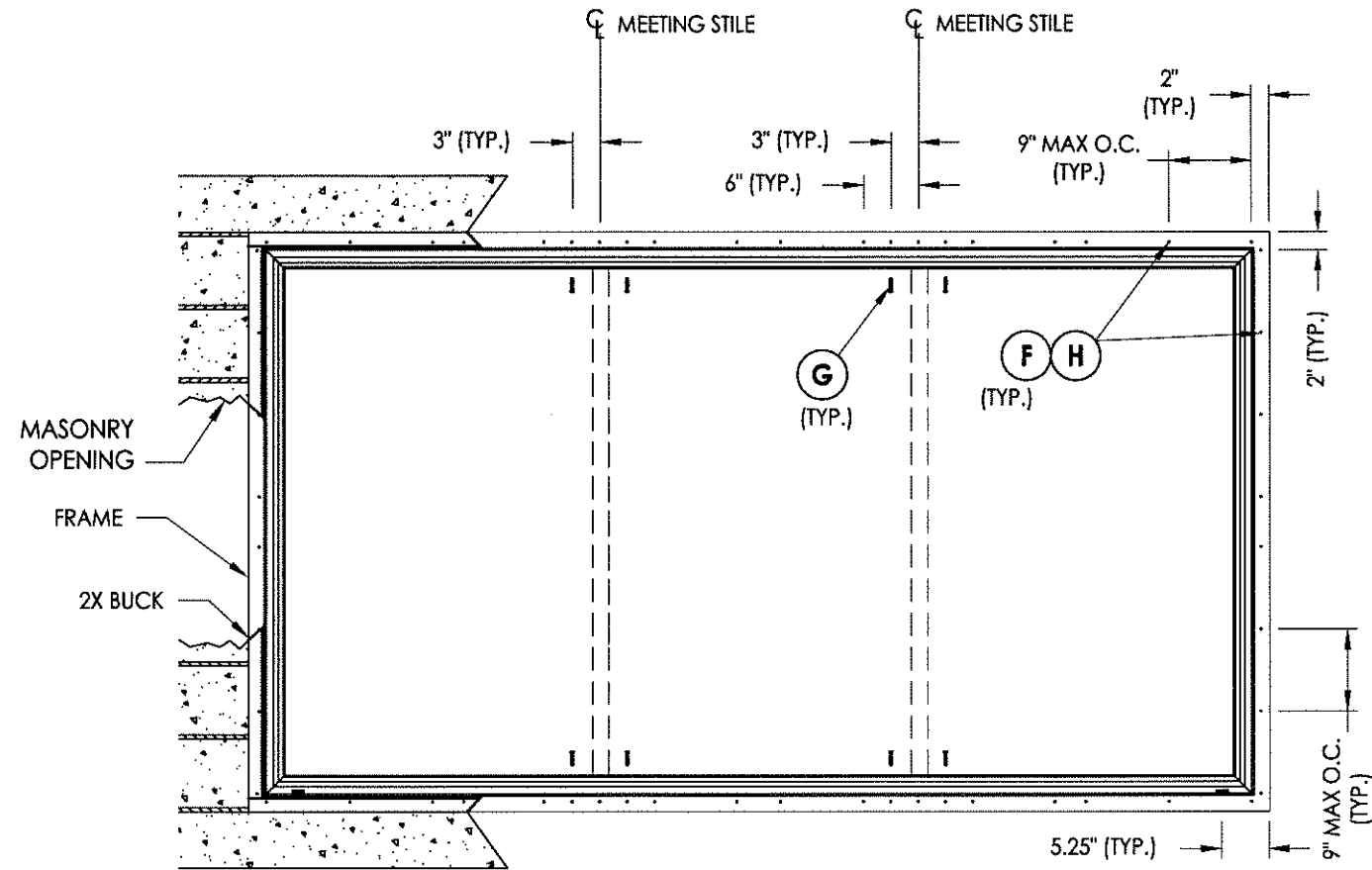

**FRAME ANCHORING**

**CONCRETE ANCHOR NOTES:**

1. Substitution of equal concrete anchors from a different supplier may have different edge distance and center distance requirements.
2. Concrete anchor locations at the corners may be adjusted to maintain the min. edge distance to mortar joints. If concrete anchor locations noted as "MAX. ON CENTER" must be adjusted to maintain the min. edge distance to mortar joints, additional concrete anchors may be required to ensure the "MAX. ON CENTER" dimensions are not exceeded.
3. Concrete anchor table:

ANCHOR TYPE	ANCHOR SIZE	MIN. EMBEDMENT	MIN. CLEARANCE TO MASONRY EDGE	MIN. CLEARANCE TO ADJACENT ANCHOR
ITW	1/4"	1-1/4"	2-1/2"	3"
ELCO	1/4"	1-1/4"	1"	4"

Documents Prepared By:

**RW** BUILDING CONSULTANTS, INC.  
 P.O. Box 230 Veroico FL 33595  
 Phone No.: 813.659.9197  
 Florida Board of Professional Engineers  
 Certificate Of Authorization No. 9813  
*RF* 10-24-13  
 Lyndon F. Schmidt, P.E. No. 43409

PRODUCT: 400 SERIES  
 1/3-1/3-1/3

PART OR ASSEMBLY:  
 BUCK AND FRAME ANCHORING

NO.	DATE	BY	REVISIONS

DATE: 10/4/13  
 SCALE: N.T.S.  
 DWG. BY: JK  
 CHK. BY: LFS  
 DRAWING NO.: FL-16092.14  
 SHEET 3 OF 4

**BILL OF MATERIALS**

ITEM #	DESCRIPTION	Part #	MATERIAL
A	1X BUCK SG >= 0.42	-	WOOD
B	2X BUCK SG >= 0.42	-	WOOD
C	1/4" MAX. SHIM SPACE	-	-
D	1/4" X 2-3/4" PFH ELCO OR ITW CONCRETE SCREW	-	STEEL
E	MASONRY - 3,192 PSI MIN. CONCRETE CONFORMING TO ACI 301 OR HOLLOW BLOCK CONFORMING TO ASTM C90	-	CONCRETE
F	#8 X 1-1/2" HWH SMS (1-3/8" EMBEDMENT)	-	STEEL
G	#10 X 1-1/2" PFH WOOD SCREW (1-1/4" EMBEDMENT)	-	STEEL
H	#8 X 1-1/2" PPH SMS (1-3/8" EMBEDMENT)	-	STEEL
1	FRAME*	DS5401E	PVC
2	SLIDER PULL STILE*	SE4647	PVC
3	LOCK STILE*	SE4646	PVC
4	KEEPER STILE*	SE4644	PVC
5	GLAZING BEAD*	22841	PVC
6	SLIDER COMMON RAIL*	SE4645	PVC
7	METAL ROLLERS w/ PLASTIC HOUSING	-	-
8	WEATHERSTRIP (0.230")	-	-
9	WEATHERSTRIP (0.380")	-	-
10	REINFORCEMENT	-	ALUM
11	SILL TRACK*	V777	PVC
15	WEEPHOLE CAP*	WEEP-1288	PVC
17	#8 X 1-1/4" PFH SMS	-	STEEL
18	#8 X 3/4" PFH WOOD SCREW	-	STEEL
19	LOWER FLANKER STOP	2991C	NYLON
20	UPPER FLANKER STOP	2991B	NYLON

\* THE APPROVED WHITE RIGID PVC EXTERIOR EXTRUSIONS FOR WINDOWS ARE TO BE PRODUCED BY EXTRUDERS LICENSEES IN "AAMA CERTIFICATION PROGRAMS FOR RIGID PVC EXTRUSIONS".

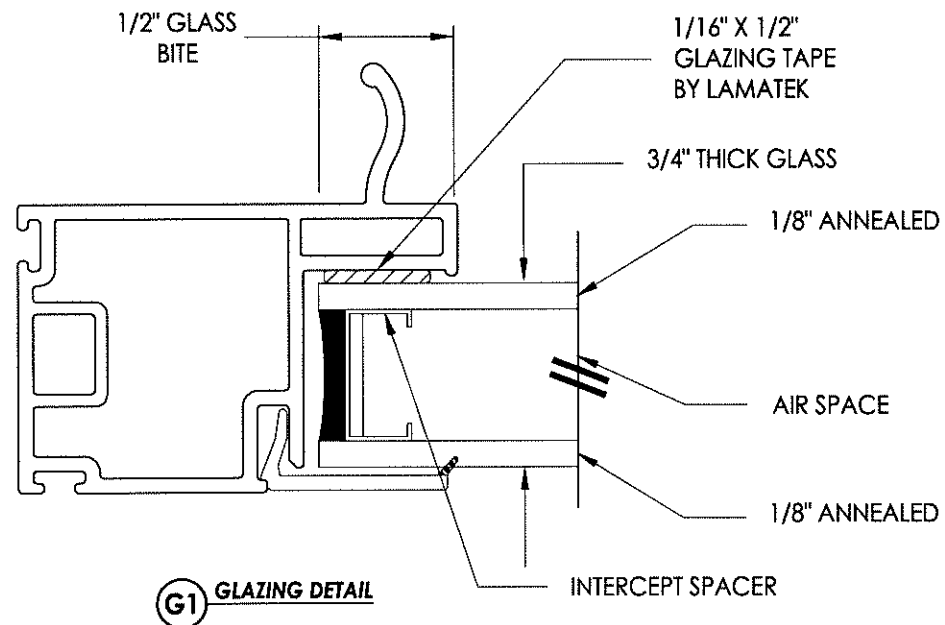
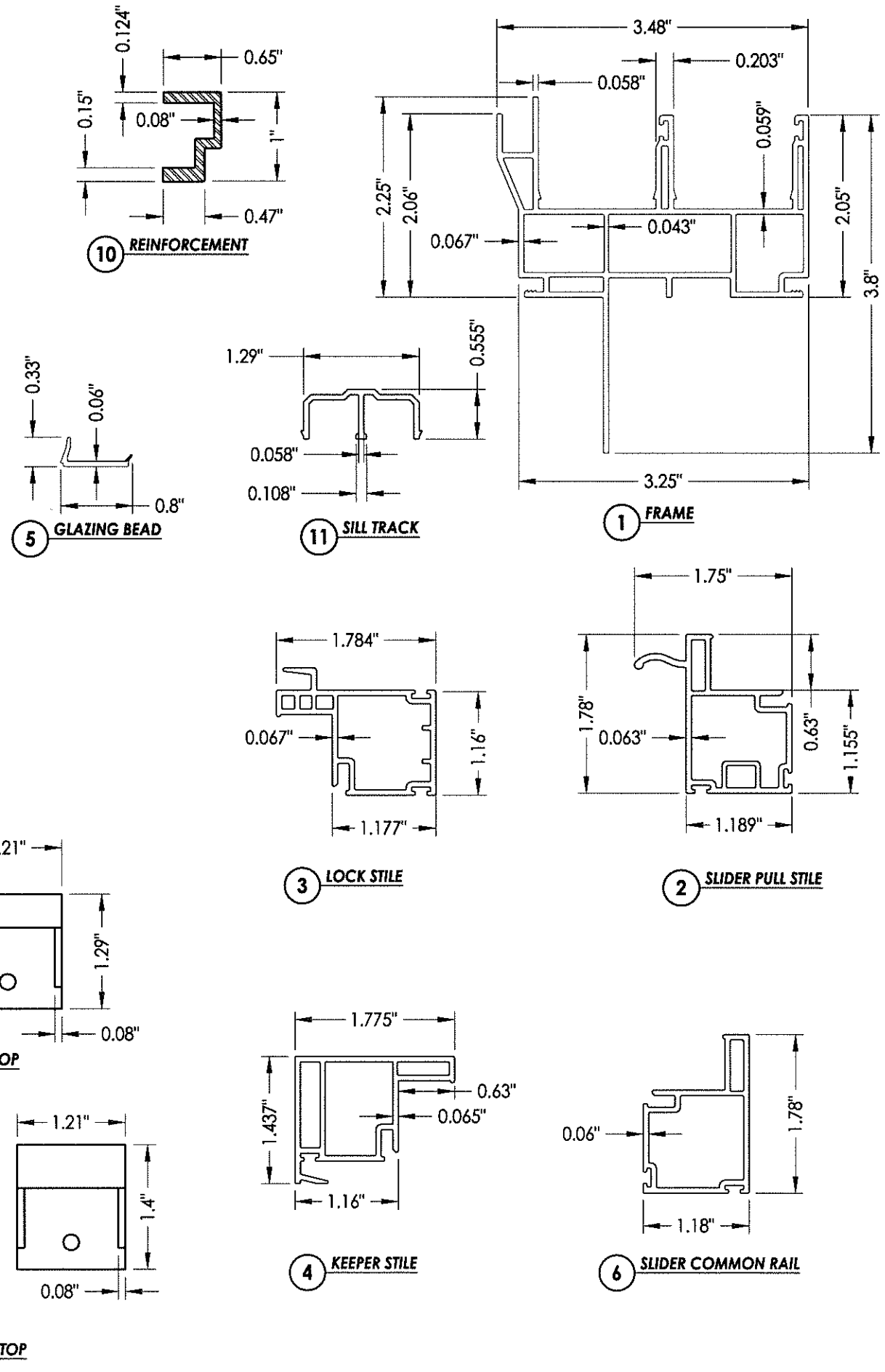

Documents Prepared By: **RW BUILDING CONSULTANTS, INC.**  
 P.O. Box 230 Valrico FL 33595  
 Phone No.: 813.659.9197  
 Florida Board of Professional Engineers  
 Certificate Of Authorization No. 9813  
 Lyndon F. Schmidt, P.E. No. 43409

PRODUCT: 400 SERIES 1/3-1/3-1/3  
 PART OR ASSEMBLY: BILL OF MATERIALS, COMPONENTS & GLAZING DETAILS

NO.	DATE	BY	REVISIONS

DATE: 10/4/13  
 SCALE: N.T.S.  
 DWG. BY: JK  
 CHK. BY: LFS  
 DRAWING NO.: FL-16092.14  
 SHEET 4 OF 4

© 2013 R.W. BUILDING CONSULTANTS INC.