

WINCORE™

WINDOWS & DOORS

250 Staunton Turnpike, Parkersburg, WV 26104

8400 Series Vinyl Horizontal Sliding Window "NON-IMPACT"

GENERAL NOTES

1. This product has been evaluated and is in compliance with the 2010 Florida Building Code (FBC) structural requirements excluding the "High Velocity Hurricane Zone" (HVHZ).
2. Product anchors shall be as listed and spaced as shown on details. Anchor embedment to base material shall be beyond wall dressing or stucco.
3. When used in areas requiring wind borne debris protection this product is required to be protected with an impact resistant covering that complies with Section 1609.1.2 of the FBC.
4. For 2x stud framing construction, anchoring of these units shall be the same as that shown for 2x buck masonry construction.
5. Site conditions that deviate from the details of this drawing require further engineering analysis by a licensed engineer or registered architect.

TABLE OF CONTENTS	
SHEET#	DESCRIPTION
1	Typical elevations, design pressures and general notes
2	Horizontal cross sections
3	Vertical cross sections
4	Buck and frame anchoring
5	Components
6	Bill of materials & glazing details

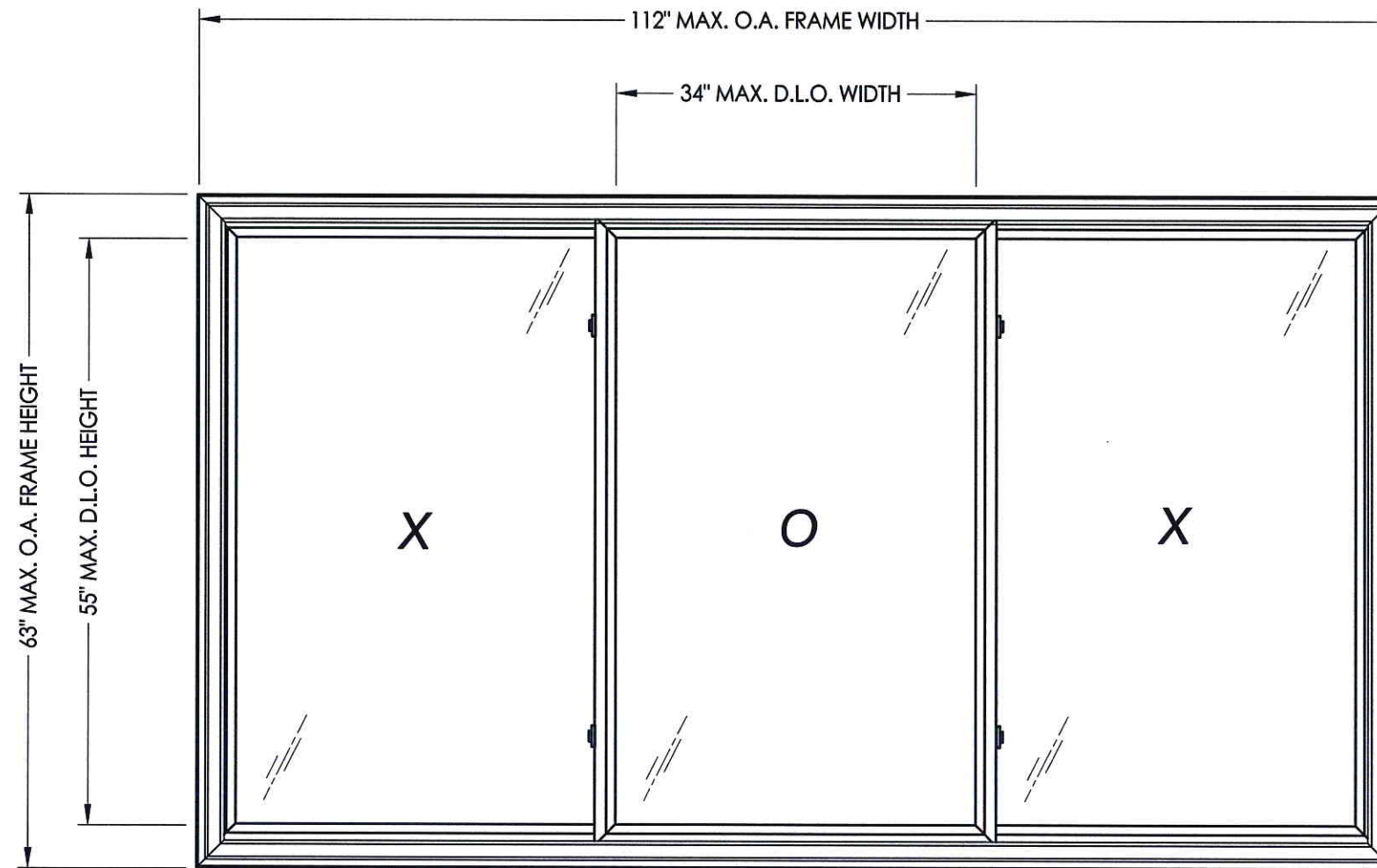

XOX SHOWN
XXX ALSO APPROVED

MAX. FRAME DIMENSION	MAX. D.L.O. DIMENSION	GLASS TYPE	DESIGN PRESSURE (PSF)	
			POSITIVE	NEGATIVE
110.0" X 62.0"	33.0" X 54.0"	G1	+50.0	-50.0

Documents Prepared By:

RW BUILDING CONSULTANTS, INC.
P.O. Box 230 Vairico FL 33595
Phone No.: 813.659.9197
Florida Board of Professional Engineers
Certificate Of Authorization No. 9813
4-22-13
Lyndon F. Schmidt, P.E. No. 43409

PRODUCT: 8400 SERIES

PART OR ASSEMBLY:
TYPICAL ELEVATION, DESIGN PRESSURES & GENERAL NOTES

NO.	DATE	BY	REVISIONS
1	4/04/13	LFS	ADD COSMETIC FLANGES

DATE: 12/05/12

SCALE: N.T.S.

DWG. BY: JK

CHK. BY: LFS

DRAWING NO.:

FL-16092.3

SHEET 1 OF 6

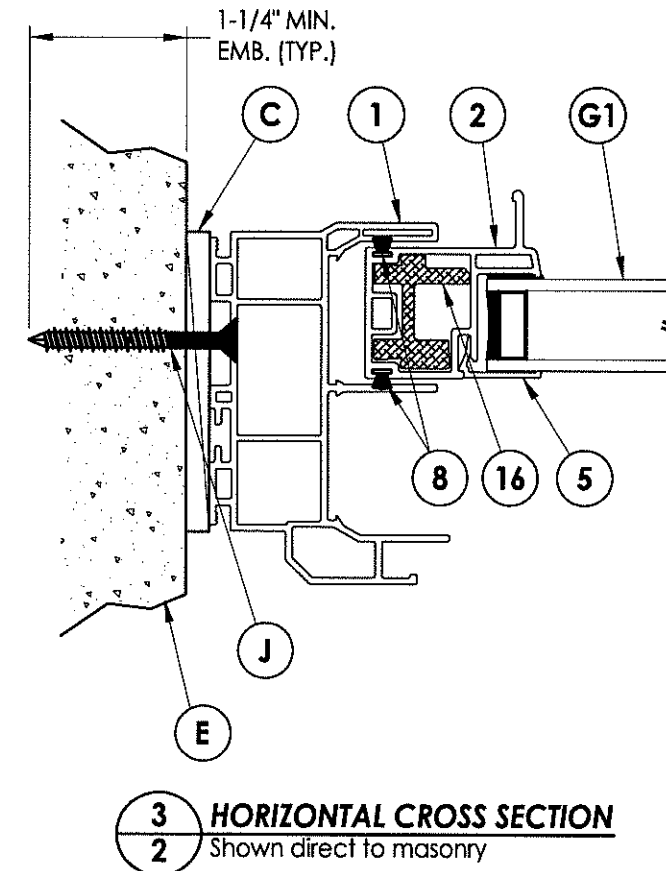
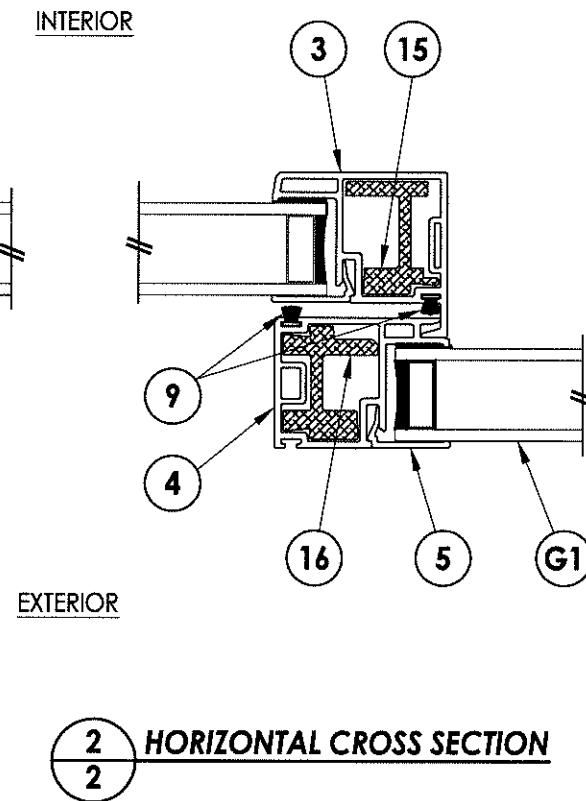
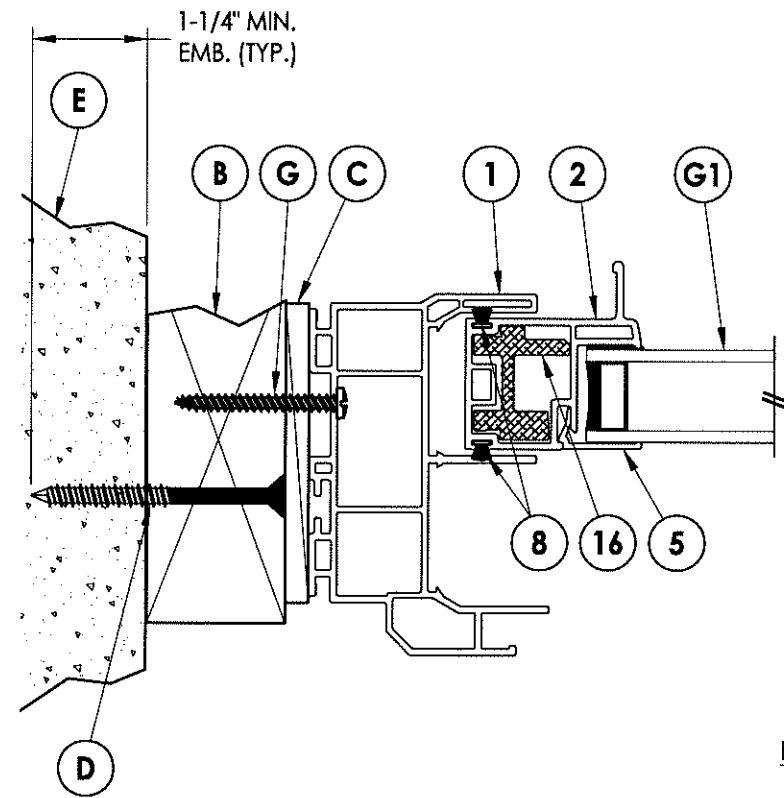
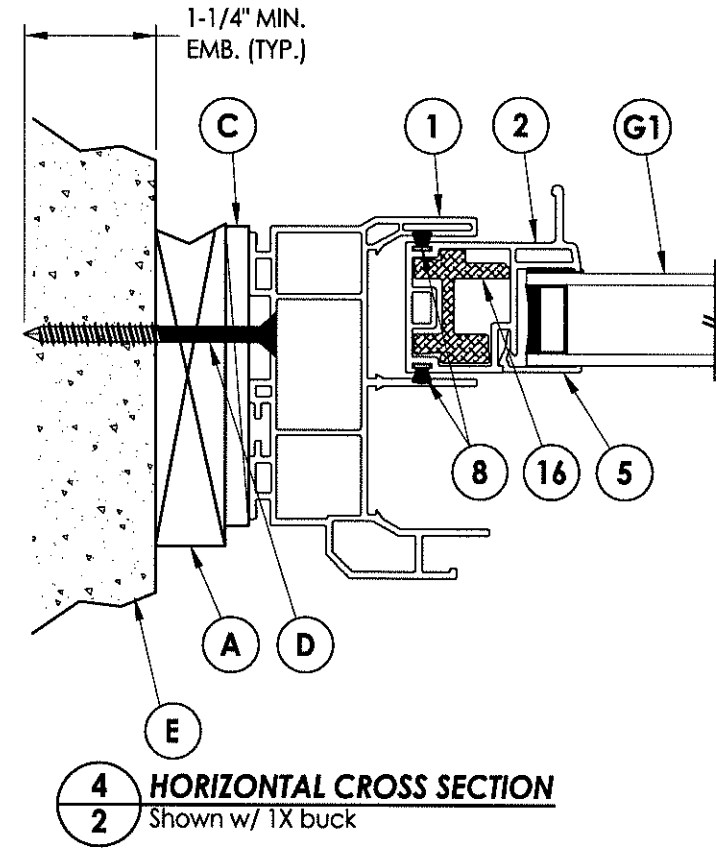
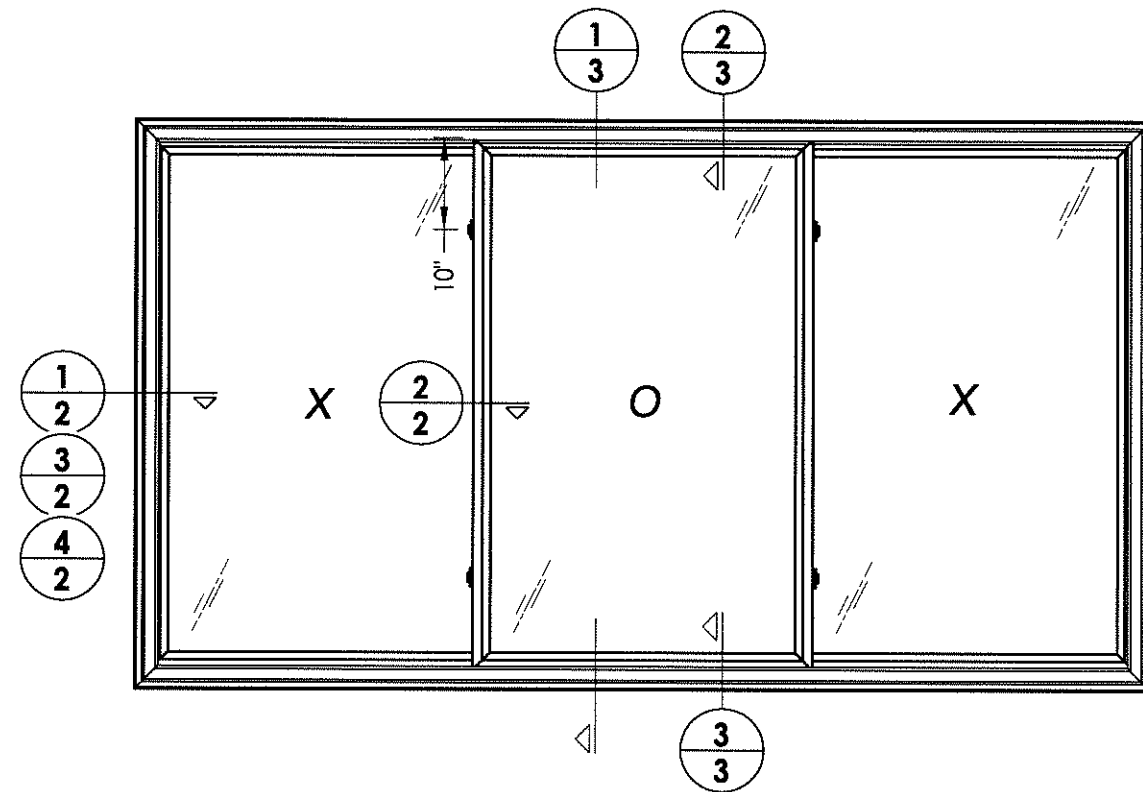

Documents Prepared By:
RW BUILDING CONSULTANTS, INC.
 P.O. Box 230 Valrico FL 33595
 Phone No.: 813.659.9197
 Florida Board of Professional Engineers
 Certificate Of Authorization No. 9813
 12/22/13
 Lyndon F. Schmidt, P.E. No. 43409

PRODUCT:	8400 SERIES	
PART OR ASSEMBLY:	HORIZONTAL CROSS SECTIONS	
NO.	DATE	BY
1	4/04/13	LFS
ADD COSMETIC FLANGES		
REVISIONS		
DATE:	12/05/12	
SCALE:	N.T.S.	
DWG. BY:	JK	
CHK. BY:	LFS	
DRAWING NO.:	FL-16092.3	
SHEET	2	OF 6

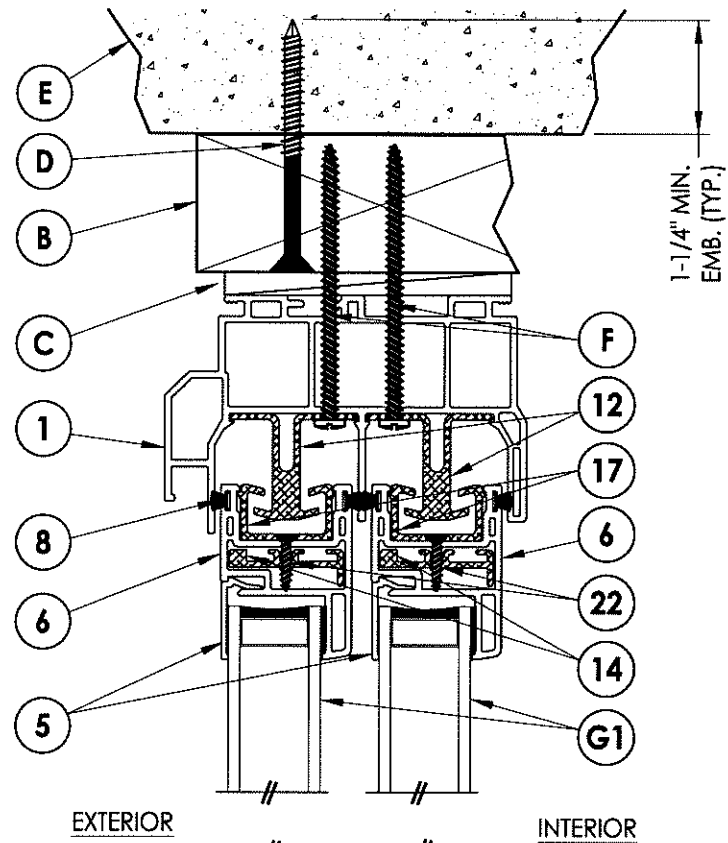

EXTERIOR // INTERIOR

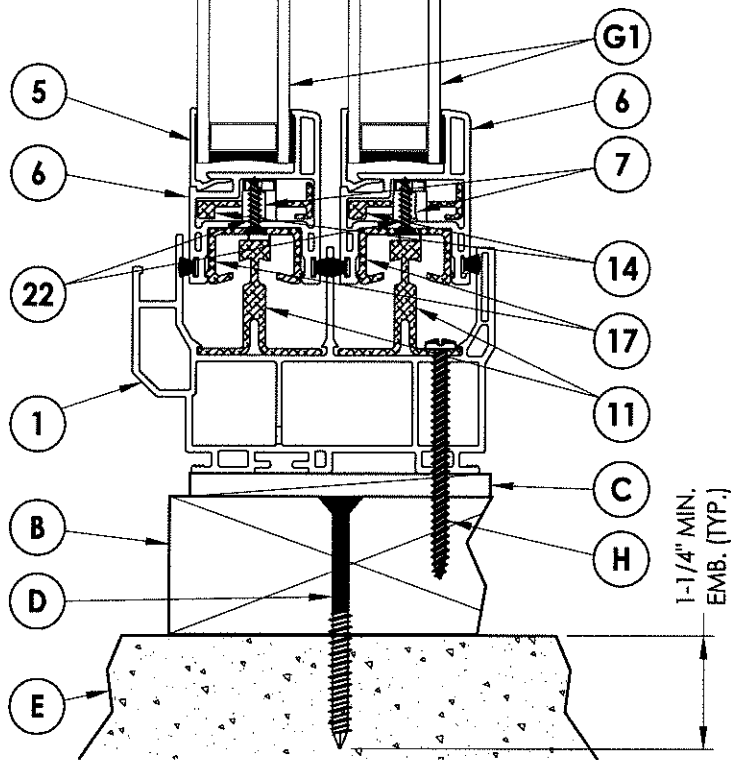

1 VERTICAL CROSS SECTION
3 Shown w/ 2X buck

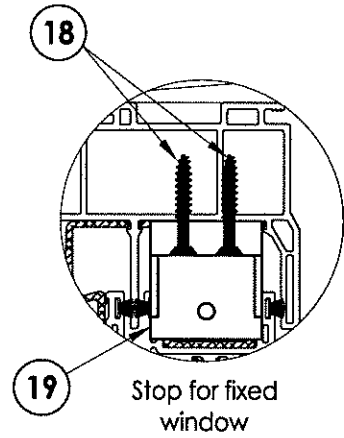

18 Stop for fixed window

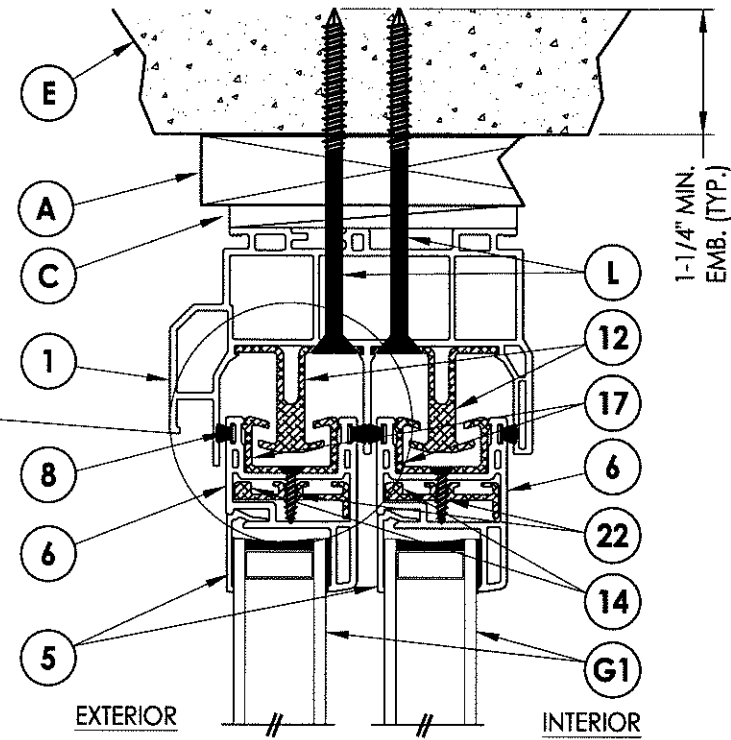

EXTERIOR // INTERIOR

2 VERTICAL CROSS SECTION
3 Shown w/ 1X buck

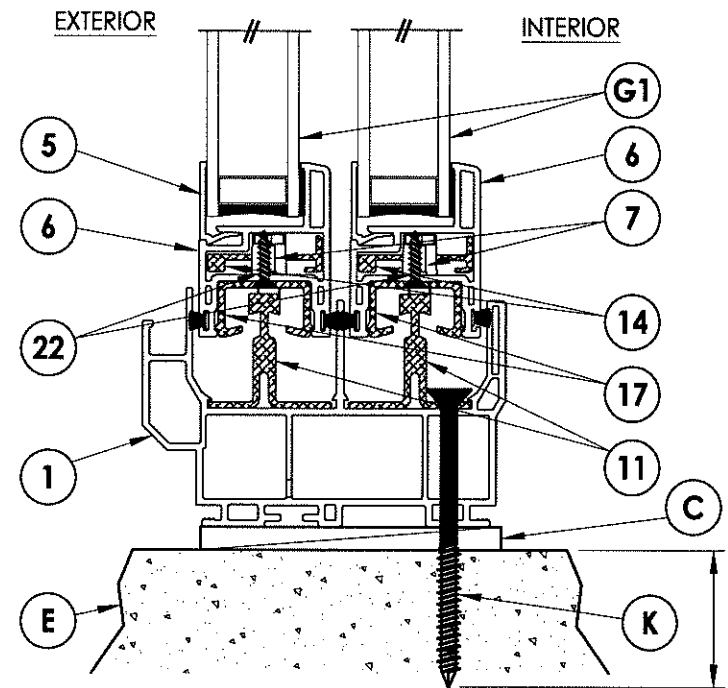

3 VERTICAL CROSS SECTION
3 Shown direct to masonry

Documents Prepared By:

R.W. BUILDING CONSULTANTS, INC.
P.O. Box 230 Valrico FL 33595
Phone No.: 813.659.9197
Florida Board of Professional Engineers
Certificate of Authorization No. 9813
LFS

Lyndon F. Schmidt, P.E. No. 43409

PRODUCT: 8400 SERIES

PART OR ASSEMBLY: VERTICAL CROSS SECTIONS

NO.	DATE	REVISIONS	LFS	BY
1	4/04/13	ADD COSMETIC FLANGES		

DATE: 12/05/12

SCALE: N.T.S.

DWG. BY: JK

CHK. BY: LFS

DRAWING NO.:

FL-16092.3

SHEET 3 OF 6

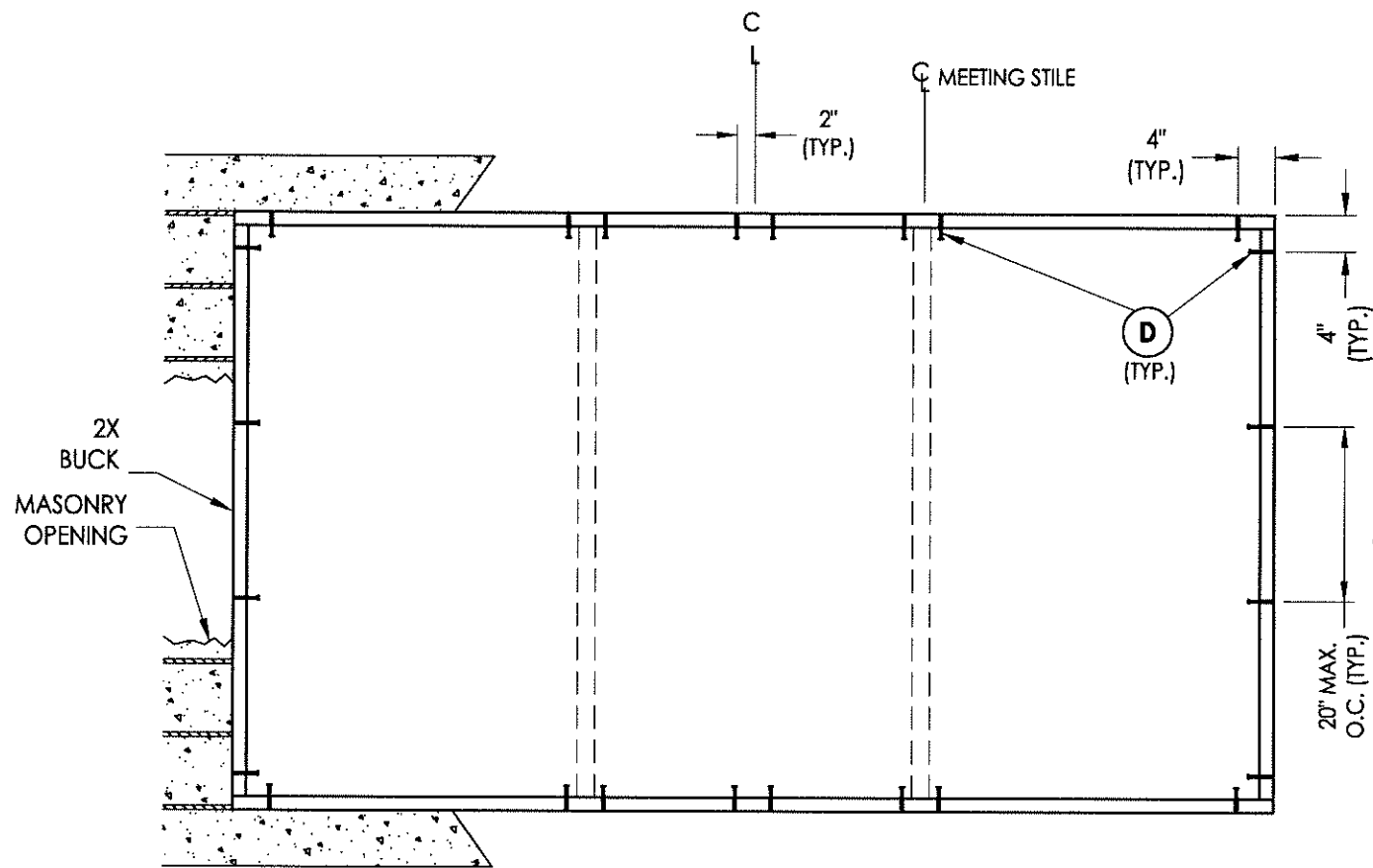

BUCK ANCHORING

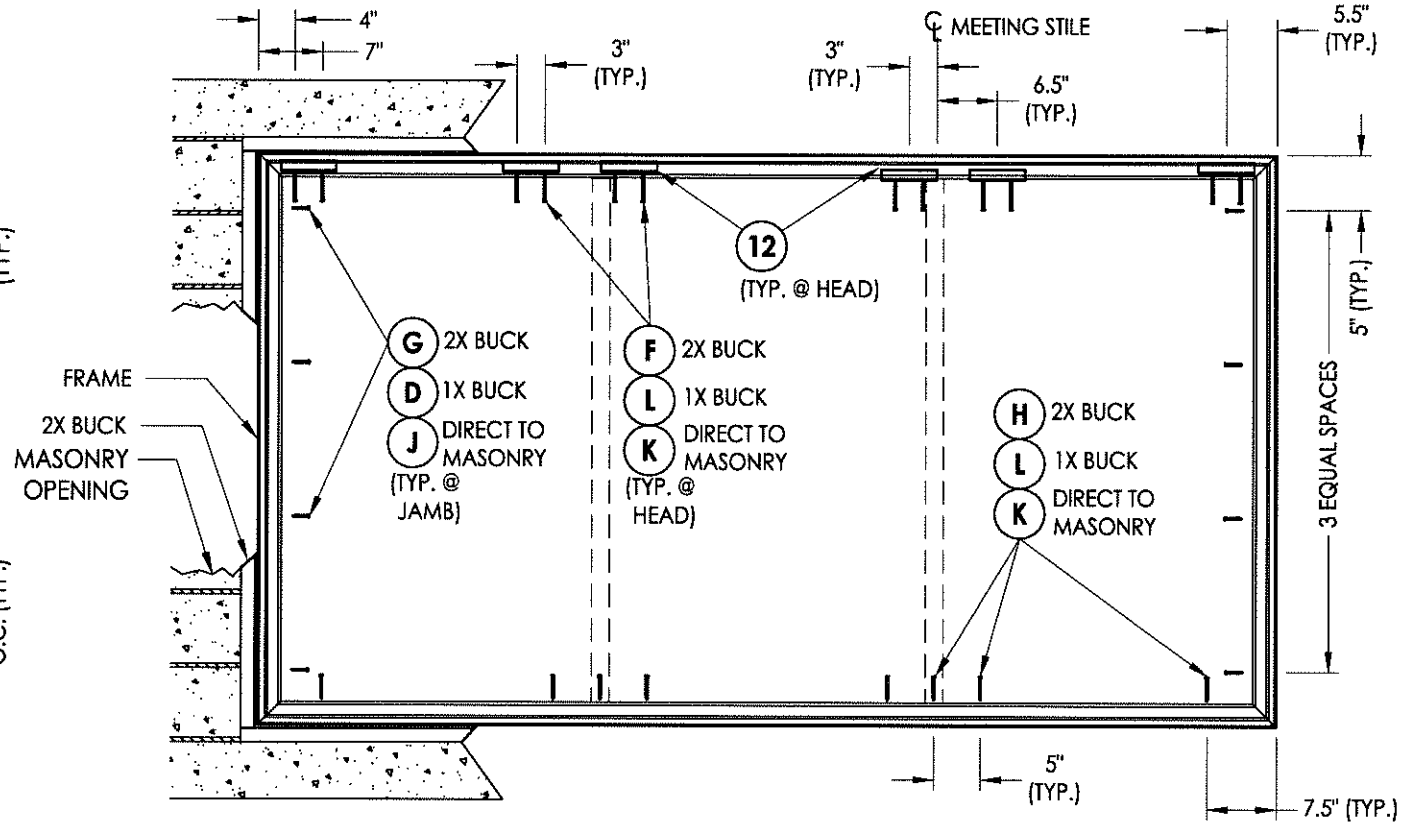

FRAME ANCHORING

CONCRETE ANCHOR NOTES:

1. Substitution of equal concrete anchors from a different supplier may have different edge distance and center distance requirements.
2. Concrete anchor locations at the corners may be adjusted to maintain the min. edge distance to mortar joints. If concrete anchor locations noted as "MAX. ON CENTER" must be adjusted to maintain the min. edge distance to mortar joints, additional concrete anchors may be required to ensure the "MAX. ON CENTER" dimensions are not exceeded.
3. Concrete anchor table:

ANCHOR TYPE	ANCHOR SIZE	MIN. EMBEDMENT	MIN. CLEARANCE TO MASONRY EDGE	MIN. CLEARANCE TO ADJACENT ANCHOR
ITW	1/4"	1-1/4"	2-1/2"	3"
ELCO	1/4"	1-1/4"	1"	4"

Documents Prepared By:

RW BUILDING CONSULTANTS, INC.
 P.O. Box 230 Valrico FL 33595
 Phone No.: 813.659.9197
 Florida Board of Professional Engineers
 Certificate Of Authorization No. 9813
 Lyndon F. Schmidt, P.E. No. 43409

PRODUCT: 8400 SERIES

PART OR ASSEMBLY:
 BUCK AND
 FRAME ANCHORING

NO.	DATE	BY	REVISIONS
1	4/04/13	LFS	ADD COSMETIC FLANGES

DATE: 12/05/12

SCALE: N.T.S.

DWG. BY: JK

CHK. BY: LFS

DRAWING NO.: FL-16092.3

SHEET 4 OF 6

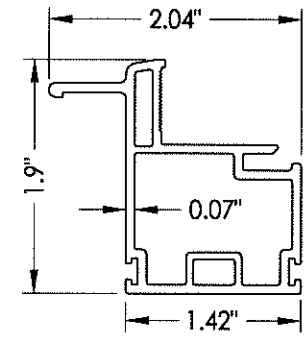

2 SLIDER PULL STILE

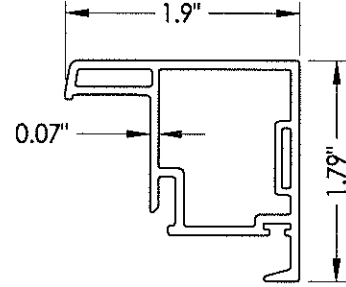

3 LOCK STILE

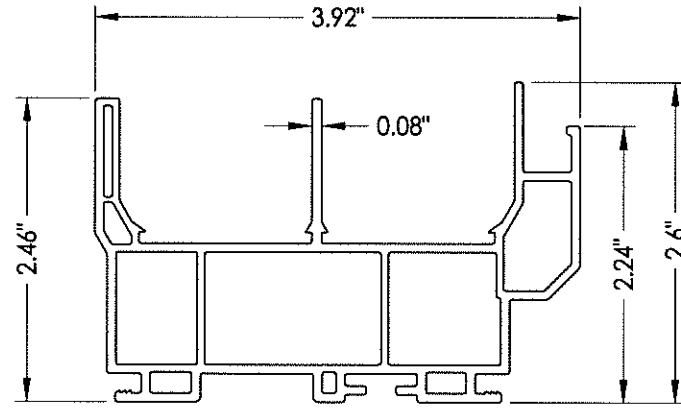

1 FRAME

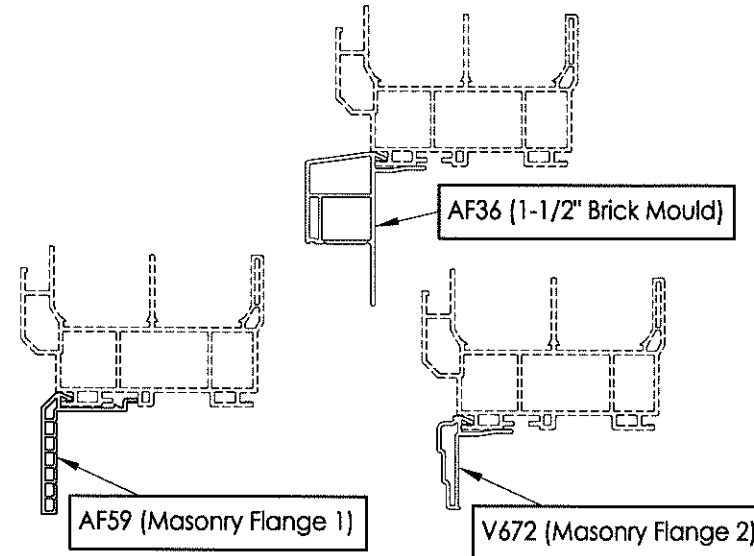

OPTIONAL COSMETIC FLANGES

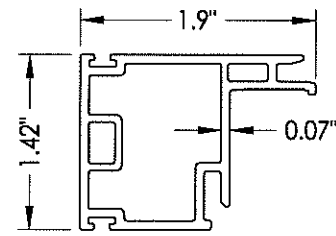

4 KEEPER STILE

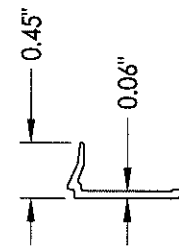

5 GLAZING BEAD

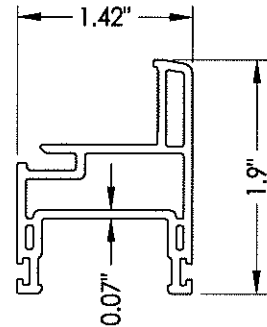

6 SLIDER COMMON RAIL

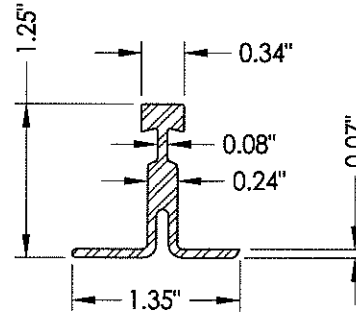

11 SILL TRACK
Full width

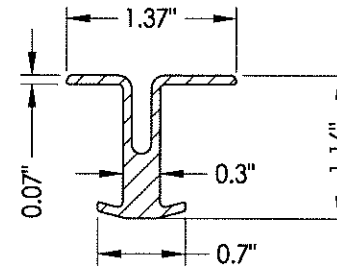

12 HEAD TRACK
6\"/>

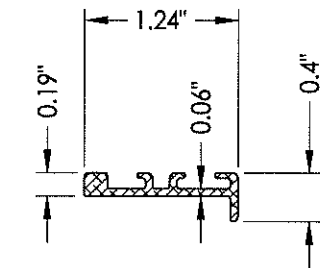

14 REINFORCEMENT
Common Rail

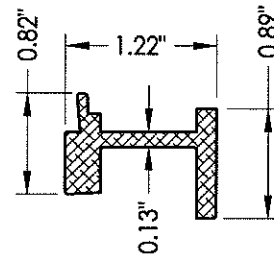

15 REINFORCEMENT
Lock Stile

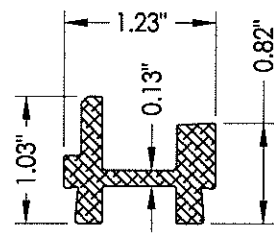

16 REINFORCEMENT
Keeper and Pull Stile

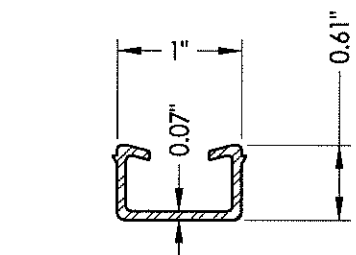

17 SLIDER SASH RETAINING CLIP

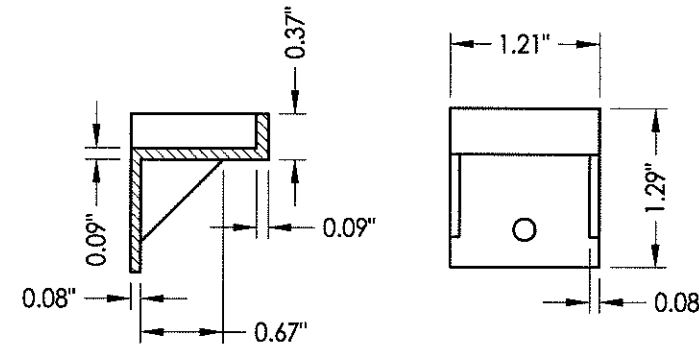

19 FLANKER STOP

Documents Prepared By:

RW BUILDING CONSULTANTS, INC.
P.O. Box 230 Valrico FL 33595
Phone No.: 813.659.9197
Florida Board of Professional Engineers
Certificate of Authorization No. 9813
2782422.13
Lyndon F. Schmidt, P.E. No. 43409

PRODUCT: 8400 SERIES

PART OR ASSEMBLY: COMPONENTS

NO.	DATE	UPDATE FRAME SIZE/DP/GLZ	LFS	BY
1	4/04/13			

REVISIONS

DATE: 12/05/12

SCALE: N.T.S.

DWG. BY: JK

CHK. BY: LFS

DRAWING NO.:

FL-16092.3

SHEET 5 OF 6

BILL OF MATERIALS		
ITEM #	DESCRIPTION	MATERIAL
A	1X BUCK SG >= 0.42	WOOD
B	2X BUCK SG >= 0.42	WOOD
C	1/4" MAX. SHIM SPACE	-
D	1/4" X 2-3/4" PFH ELCO OR ITW CONCRETE SCREW	STEEL
E	MASONRY - 3,192 PSI MIN. CONCRETE CONFORMING TO ACI 301 OR HOLLOW BLOCK CONFORMING TO ASTM C90	CONCRETE
F	#10 X 3" PPH WOOD SCREW	STEEL
G	#10 X 1-3/4" PPH WOOD SCREW	STEEL
H	#10 X 2-1/2" PPH WOOD SCREW	STEEL
J	1/4" X 2-1/4" ITW CONCRETE SCREW	STEEL
K	1/4" X 3-1/4" ITW CONCRETE SCREW	STEEL
L	1/4" X 3-3/4" ITW CONCRETE SCREW	STEEL
1	FRAME*	PVC
2	SLIDER PULL STILE*	PVC
3	LOCK STILE*	PVC
4	KEEPER STILE*	PVC
5	GLAZING BEAD*	PVC
6	SLIDER COMMON RAIL*	PVC
7	BALL BEARING ROLLER	-
8	WEATHERSTRIP (0.230")	-
9	WEATHERSTRIP (0.380")	-
11	SILL TRACK	ALUM
12	HEAD TRACK	ALUM
14	SLIDE RAIL REINFORCEMENT	ALUM
15	REINFORCEMENT	ALUM
16	REINFORCEMENT	ALUM
17	SLIDER SASH RETAINING CLIP	ALUM
18	#8 X 1" PFH SMS	STEEL
19	FLANKER STOP	NYLON
22	#8 X 5/8" (#6 head) PFH SMS	STEEL

* THE APPROVED WHITE RIGID PVC EXTERIOR EXTRUSIONS FOR WINDOWS ARE TO BE PRODUCED BY EXTRUDERS LICENSEES IN "AAMA CERTIFICATION PROGRAMS FOR RIGID PVC EXTRUSIONS".

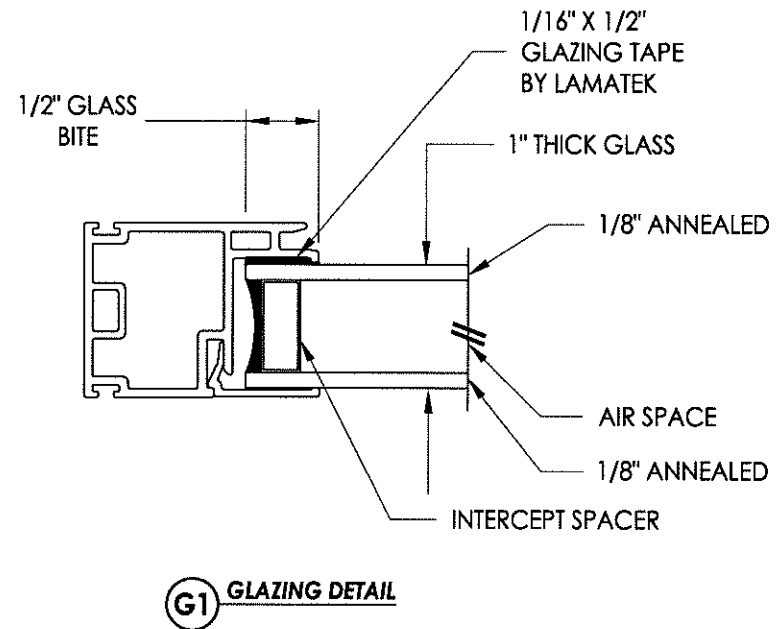

Documents Prepared By:
R.W. BUILDING CONSULTANTS, INC.
 P.O. Box 230 Valrico FL 33595
 Phone No.: 813.659.9197
 Florida Board of Professional Engineers
 Certificate Of Authorization No. 9813
 17924.22.15
 Lyndon F. Schmidt, P.E. No. 43409

PRODUCT: 8400 SERIES
 PART OR ASSEMBLY: BILL OF MATERIALS & GLAZING DETAILS

NO.	DATE	ADD COSMETIC FLANGES	BY
1	4/04/13		LFS

DATE: 12/05/12
 SCALE: N.T.S.
 DWG. BY: JK
 CHK. BY: LFS
 DRAWING NO.: FL-16092.3