

# WINCORE™

## WINDOWS & DOORS

250 Staunton Turnpike, Parkersburg, WV 26104

### 8800 Series ("HVHZ") Vinyl Fixed Window "IMPACT"

#### GENERAL NOTES

1. This product has been evaluated and is in compliance with the 2010 Florida Building Code (FBC) structural requirements including the "High Velocity Hurricane Zone" (HVHZ).
2. Product anchors shall be as listed and spaced as shown on details. Anchor embedment to base material shall be beyond wall dressing or stucco.
3. When used in the "HVHZ", this product complies with Section 1626 of the FBC and does not require an impact resistant covering.
4. For 2x stud framing construction, anchoring of these units shall be the same as that shown for 2x buck masonry construction.
5. Site conditions that deviate from the details of this drawing require further engineering analysis by a licensed engineer or registered architect.
6. This product meets the water infiltration requirements for the "HVHZ".

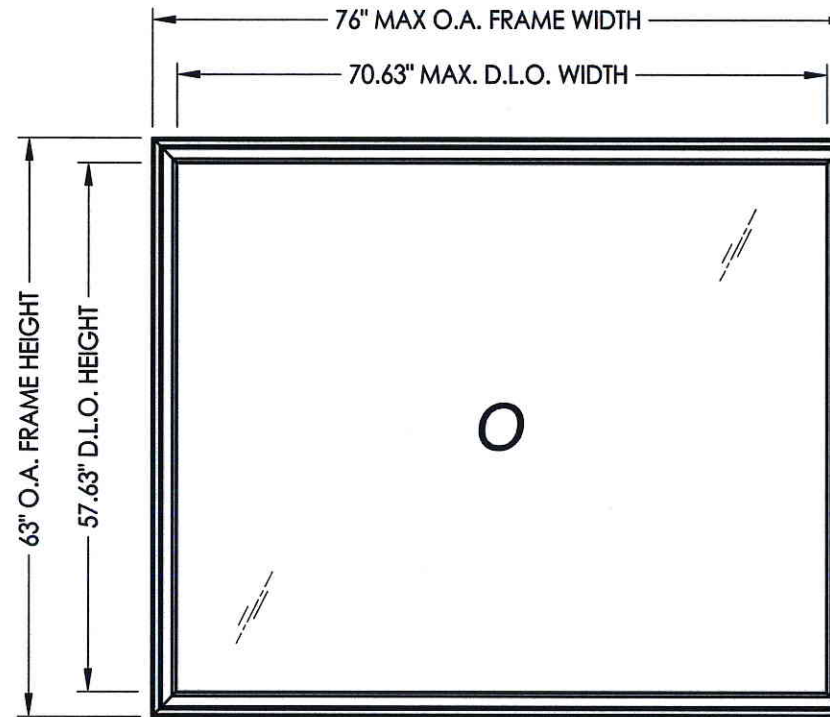

TABLE OF CONTENTS	
SHEET#	DESCRIPTION
1	Typical elevations, design pressures and general notes
2	Horizontal cross sections
3	Buck & frame anchoring
4	Bill of materials, components and glazing detail

MAX. FRAME DIMENSION	MAX. D.L.O. DIMENSION	GLASS TYPE	DESIGN PRESSURE (PSF)	
			POSITIVE	NEGATIVE
76.0" X 63.0"	70.63" X 57.63"	G1	+65.0	-70.0

Documents Prepared By:

**RW** BUILDING CONSULTANTS, INC.  
P.O. Box 230 Valrico FL 33595  
Phone No.: 813.659.9197  
Florida Board of Professional Engineers  
Certificate Of Authorization No. 9813  
*LFS*

Lyndon F. Schmidt, P.E. No. 43409

PRODUCT: 8800 SERIES VINYL FIXED WINDOW  
PART OR ASSEMBLY: TYPICAL ELEVATION, DESIGN PRESSURES & GENERAL NOTES

NO.	DATE	BY	REVISIONS

DATE: 4/09/13  
SCALE: N.T.S.  
DWG. BY: JK  
CHK. BY: LFS  
DRAWING NO.: FL-15816.4  
SHEET 1 OF 4

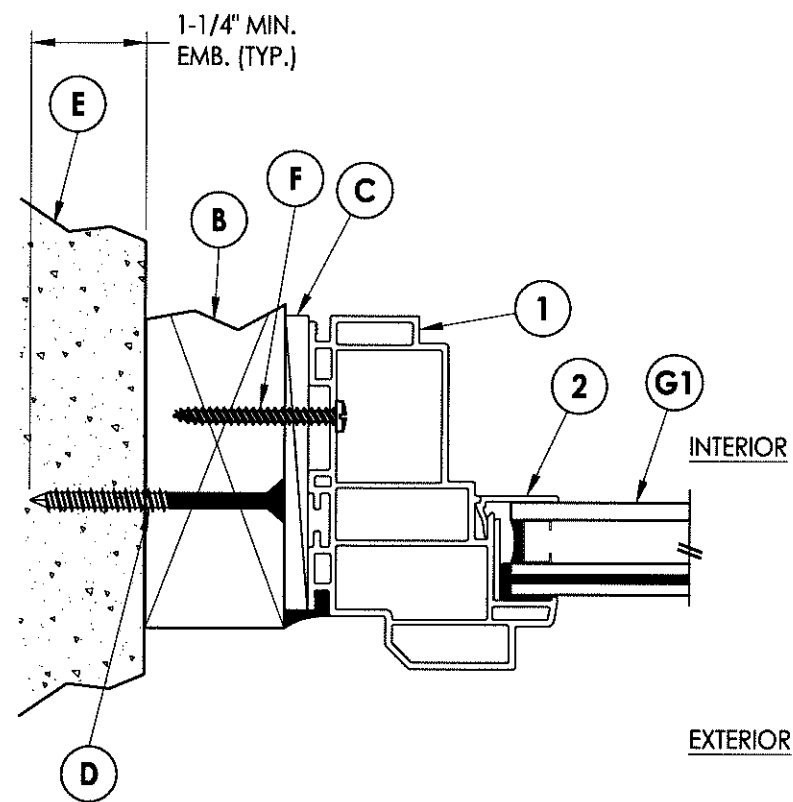

**1 HORIZONTAL CROSS SECTION**  
**2** Shown w/ 2X buck

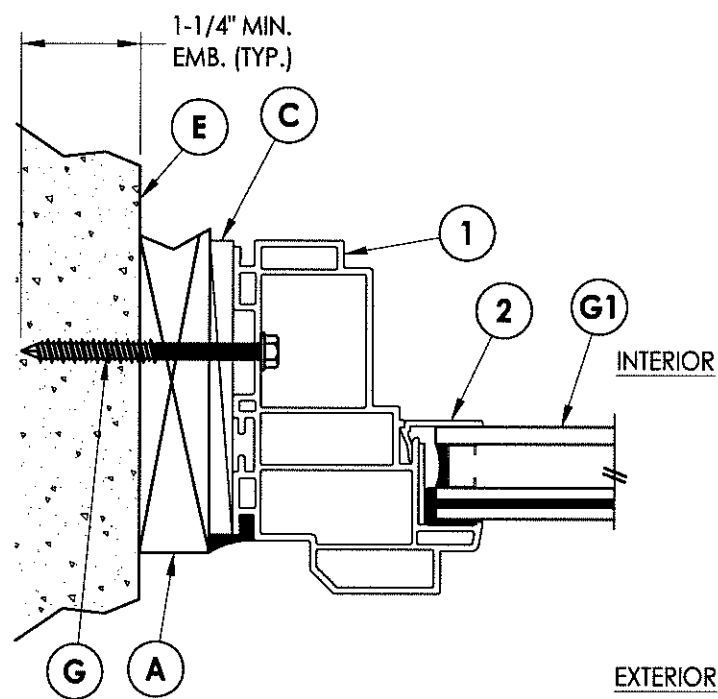

**2 HORIZONTAL CROSS SECTION**  
**2** Shown w/ 1X buck

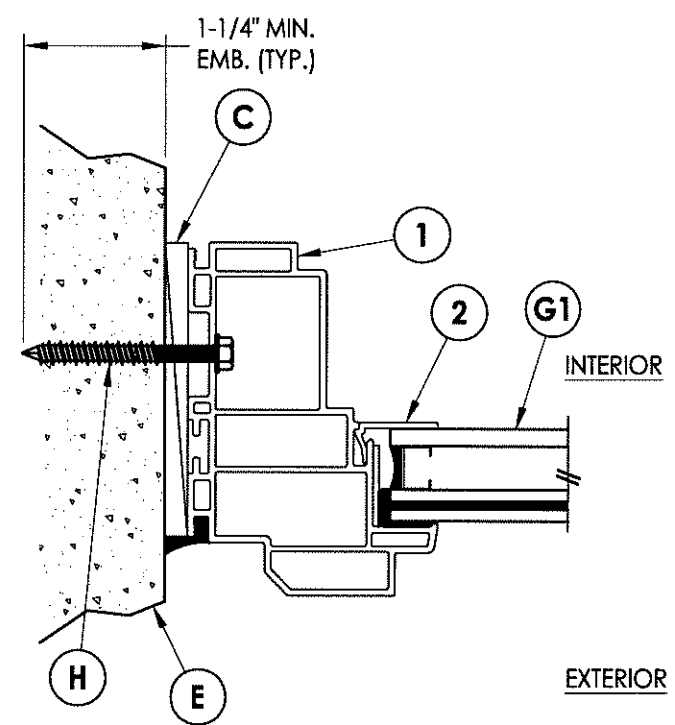

**3 HORIZONTAL CROSS SECTION**  
**2** Shown direct to masonry

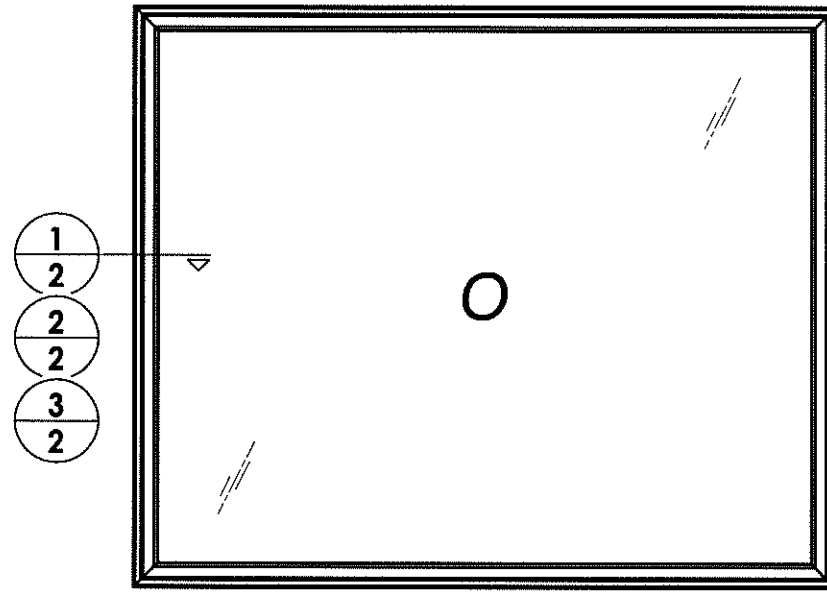

DATE:	4/09/13
SCALE:	N.T.S.
DWG. BY:	JK
CHK. BY:	LFS
DRAWING NO.:	FL-15816.4
SHEET	2 OF 4

NO.	DATE	BY	REVISIONS

PRODUCT:	8800 SERIES VINYL FIXED WINDOW
PART OR ASSEMBLY:	HORIZONTAL CROSS SECTIONS

Documents Prepared By:  
**RW** BUILDING CONSULTANTS, INC.  
 P.O. Box 230 Valrico FL 33595  
 Phone No.: 813.659.9197  
 Florida Board of Professional Engineers  
 Certificate of Authorization No. 9813  
*LFS* 5.2.13  
 Lyndon F. Schmidt, P.E. No. 43409

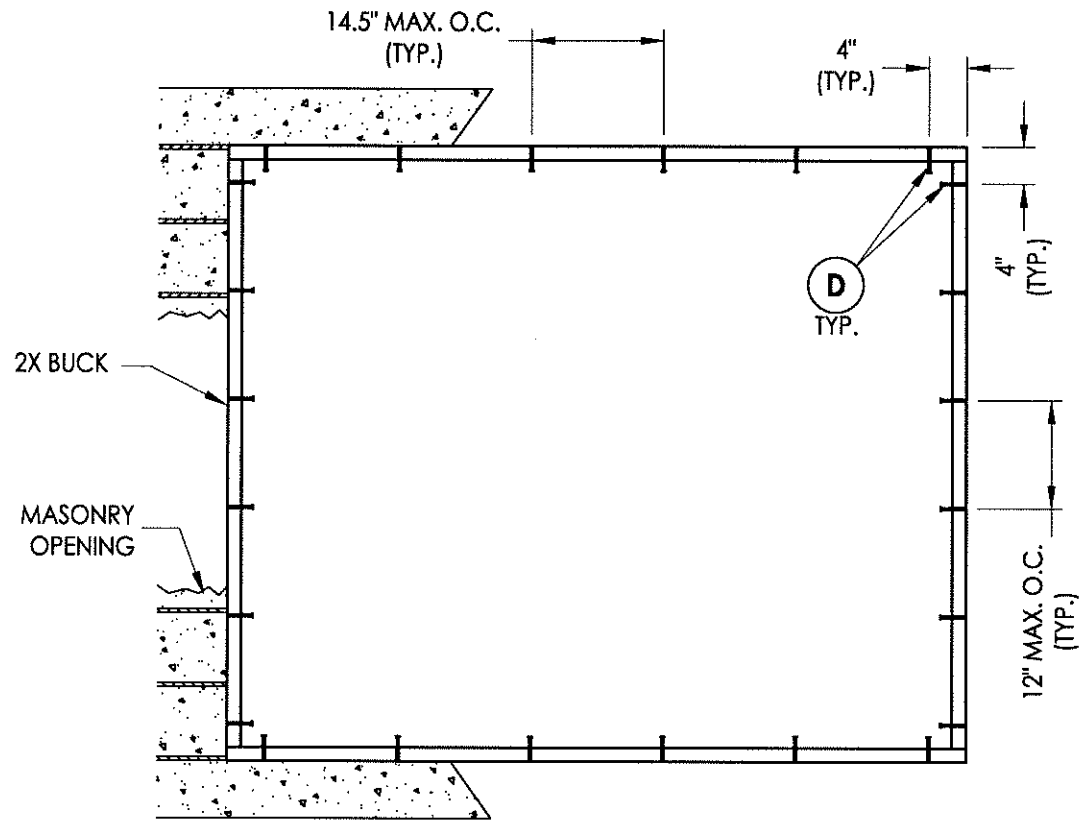

**BUCK ANCHORING**  
76" X 63" MAX  
DP ≤ 50 PSF

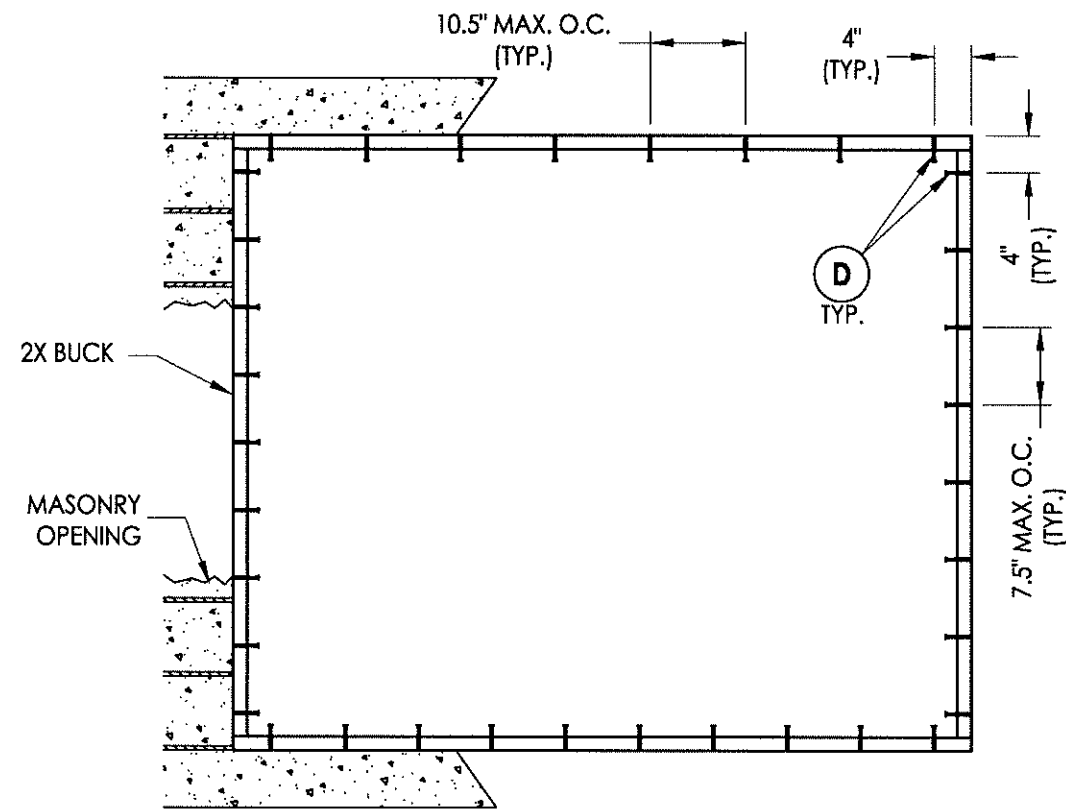

**BUCK ANCHORING**  
76" X 63" MAX  
DP ≤ 70 PSF

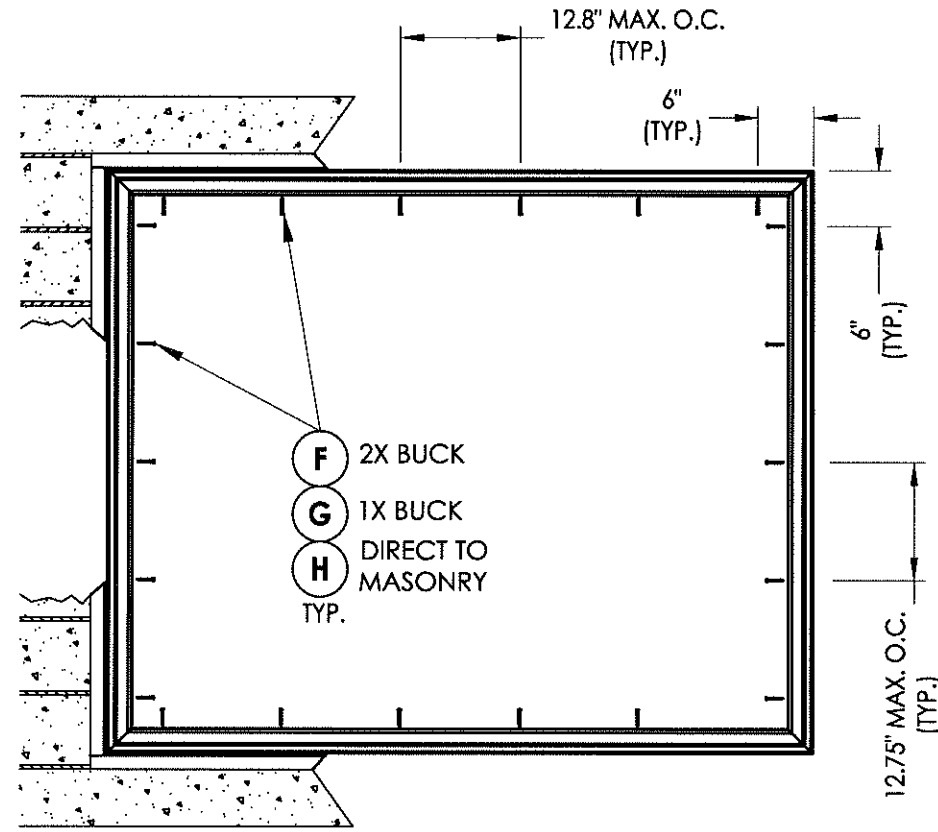

**FRAME ANCHORING**  
72" X 63" MAX

**CONCRETE ANCHOR NOTES:**

1. Substitution of equal concrete anchors from a different supplier may have different edge distance and center distance requirements.
2. Concrete anchor locations at the corners may be adjusted to maintain the min. edge distance to mortar joints. If concrete anchor locations noted as "MAX. ON CENTER" must be adjusted to maintain the min. edge distance to mortar joints, additional concrete anchors may be required to ensure the "MAX. ON CENTER" dimensions are not exceeded.
3. Concrete anchor table:

ANCHOR TYPE	ANCHOR SIZE	MIN. EMBEDMENT	MIN. CLEARANCE TO MASONRY EDGE	MIN. CLEARANCE TO ADJACENT ANCHOR
ITW	1/4"	1-1/4"	2-1/2"	3"
ELCO	1/4"	1-1/4"	1"	4"

Documents Prepared By:

**RW** BUILDING CONSULTANTS, INC.  
P.O. Box 230 Valrico FL, 33595  
Phone No.: 813.659.9197  
Florida Board of Professional Engineers  
Certificate Of Authorization No. 9813

*LFS* 5.2.13  
Lyndon F. Schmidt, P.E. No. 43409

PRODUCT: 8800 SERIES VINYL FIXED WINDOW

PART OR ASSEMBLY: BUCK & FRAME ANCHORING

NO.	DATE	REVISIONS	BY

DATE: 4/09/13

SCALE: N.T.S.

DWG. BY: JK

CHK. BY: LFS

DRAWING NO.: FL-15816.4

SHEET 3 OF 4

**BILL OF MATERIALS**

ITEM #	DESCRIPTION	MATERIAL
A	1X BUCK SG >= 0.55	WOOD
B	2X BUCK SG >= 0.55	WOOD
C	1/4" MAX. SHIM SPACE	-
D	1/4" X 2-3/4" PFH ELCO OR ITW CONCRETE SCREW	STEEL
E	MASONRY - 3,192 PSI MIN. CONCRETE CONFORMING TO ACI 301 OR HOLLOW BLOCK CONFORMING TO ASTM C90	CONCRETE
F	#10 X 1-3/4" PPH WOOD SCREW	STEEL
G	1/4" X 2-3/4" HWH ELCO OR ITW CONCRETE SCREW	STEEL
H	1/4" X 2-1/4" HWH ELCO OR ITW CONCRETE SCREW	STEEL
1	FRAME (PI7701WH)*	PVC
2	1" GLAZING BEAD (BV56WH)*	PVC

\* THE APPROVED WHITE RIGID PVC EXTERIOR EXTRUSIONS FOR WINDOWS ARE TO BE PRODUCED BY EXTRUDERS LICENSEES IN "AAMA CERTIFICATION PROGRAMS FOR RIGID PVC EXTRUSIONS".

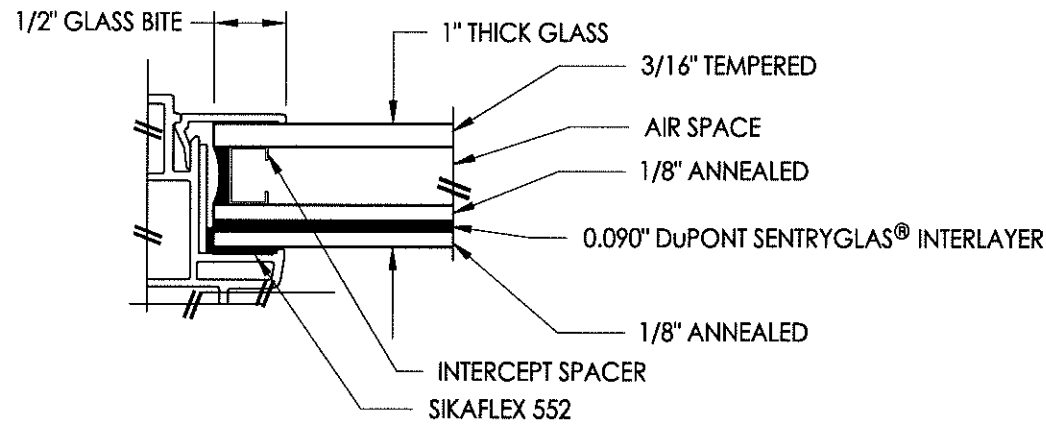
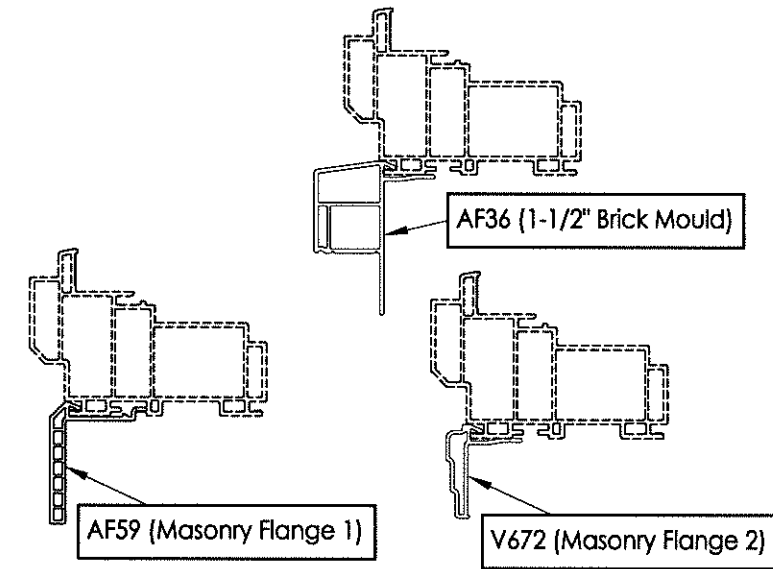
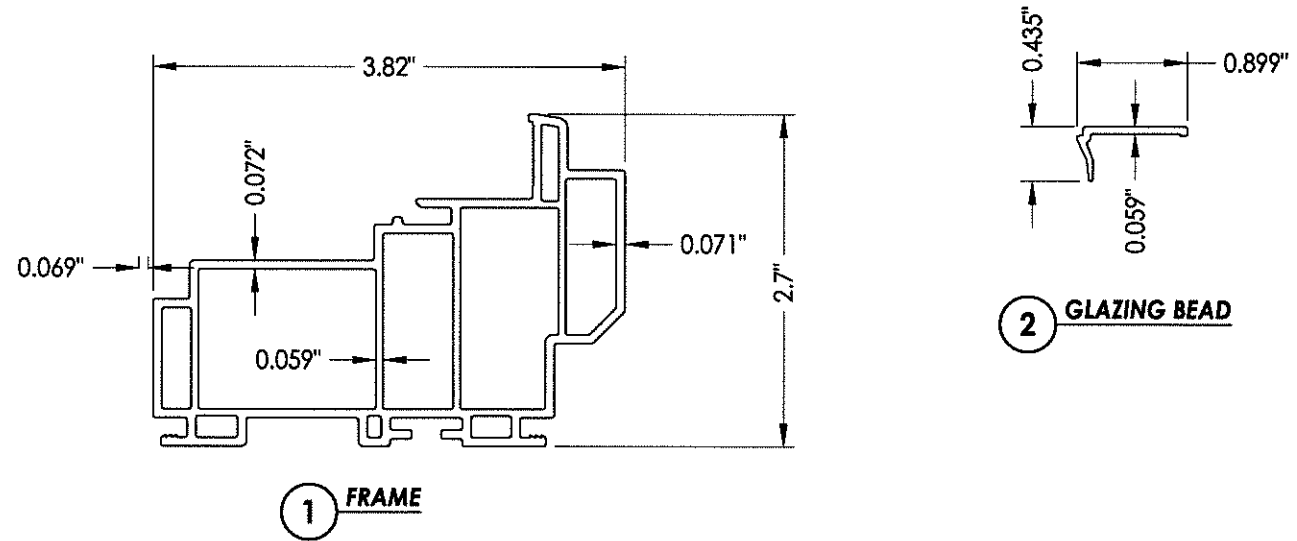

**OPTIONAL COSMETIC FLANGES**

Documents Prepared By:

RW BUILDING CONSULTANTS, INC.  
 P.O. Box 230 Valrico FL 33595  
 Phone No.: 813.659.9197  
 Florida Board of Professional Engineers  
 Certificate of Authorization No. 9813  
 Lyndon F. Schmidt, P.E. No. 43409

PRODUCT: 8800 SERIES VINYL FIXED WINDOW  
 PART OR ASSEMBLY: BILL OF MATERIALS, COMPONENTS AND GLAZING DETAIL

NO	DATE	BY	REVISIONS

DATE: 4/09/13  
 SCALE: N.T.S.  
 DWG. BY: JK  
 CHK. BY: LFS  
 DRAWING NO.: FL-15816.4

SHEET 4 OF 4