

WINCORE™

WINDOWS & DOORS

250 Staunton Turnpike, Parkersburg, WV 26104

8800 Series Vinyl Sliding Patio Door "IMPACT"

GENERAL NOTES

1. This product has been evaluated and is in compliance with the 2010 Florida Building Code (FBC) structural requirements including the "High Velocity Hurricane Zone" (HVHZ).
2. Product anchors shall be as listed and spaced as shown on details. Anchor embedment to base material shall be beyond wall dressing or stucco.
3. When used in the "HVHZ", this product complies with Section 1626 of the FBC and does not require an impact resistant covering.
4. For 2x stud framing construction, anchoring of these units shall be the same as that shown for 2x buck masonry construction.
5. Site conditions that deviate from the details of this drawing require further engineering analysis by a licensed engineer or registered architect.
6. This product meets the water infiltration requirements for the "HVHZ".

TABLE OF CONTENTS

| SHEET# | DESCRIPTION |
|--------|---|
| 1 | Typical elevation, design pressures & general notes |
| 2 | Horizontal and vertical cross sections |
| 3 | Buck & frame anchoring |
| 4 | Glazing detail & components |
| 5 | Bill of materials |

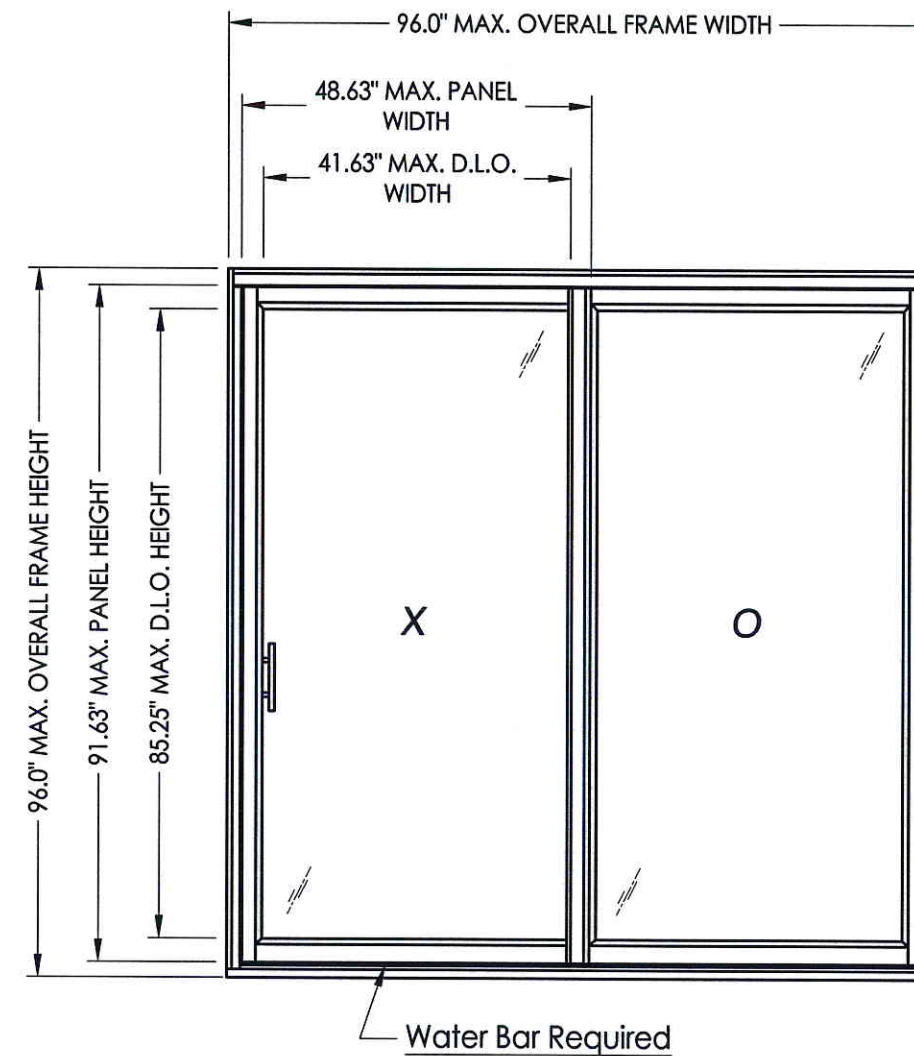

| OVERALL FRAME DIMENSION | MAX. PANEL DIMENSION | MAX. D.L.O. DIMENSION | DESIGN PRESSURE (PSF) | |
|-------------------------|----------------------|-----------------------|-----------------------|----------|
| | | | POSITIVE | NEGATIVE |
| 96.0" x 96.0" | 48.63" X 91.63" | 41.63" X 85.25" | +50.0 | -55.0 |

Documents Prepared By:

RW BUILDING CONSULTANTS, INC.
P.O. Box 230 Valrico FL 33595
Phone No.: 813.659.9197
Florida Board of Professional Engineers
Certificate Of Authorization No. 9813
4/20/13
Lyndon F. Schmidt, P.E. No. 43409

PRODUCT: 8800 SERIES VINYL SLIDING PATIO DOORS
PART OR ASSEMBLY: TYPICAL ELEVATION, DESIGN PRESSURES & GENERAL NOTES

| NO. | DATE | BY | REVISIONS |
|-----|------|----|-----------|
| | | | |
| | | | |
| | | | |

DATE: 4/02/13
SCALE: N.T.S.
DWG. BY: JK
CHK. BY: LFS
DRAWING NO.: FL-16216.3
SHEET 1 OF 5

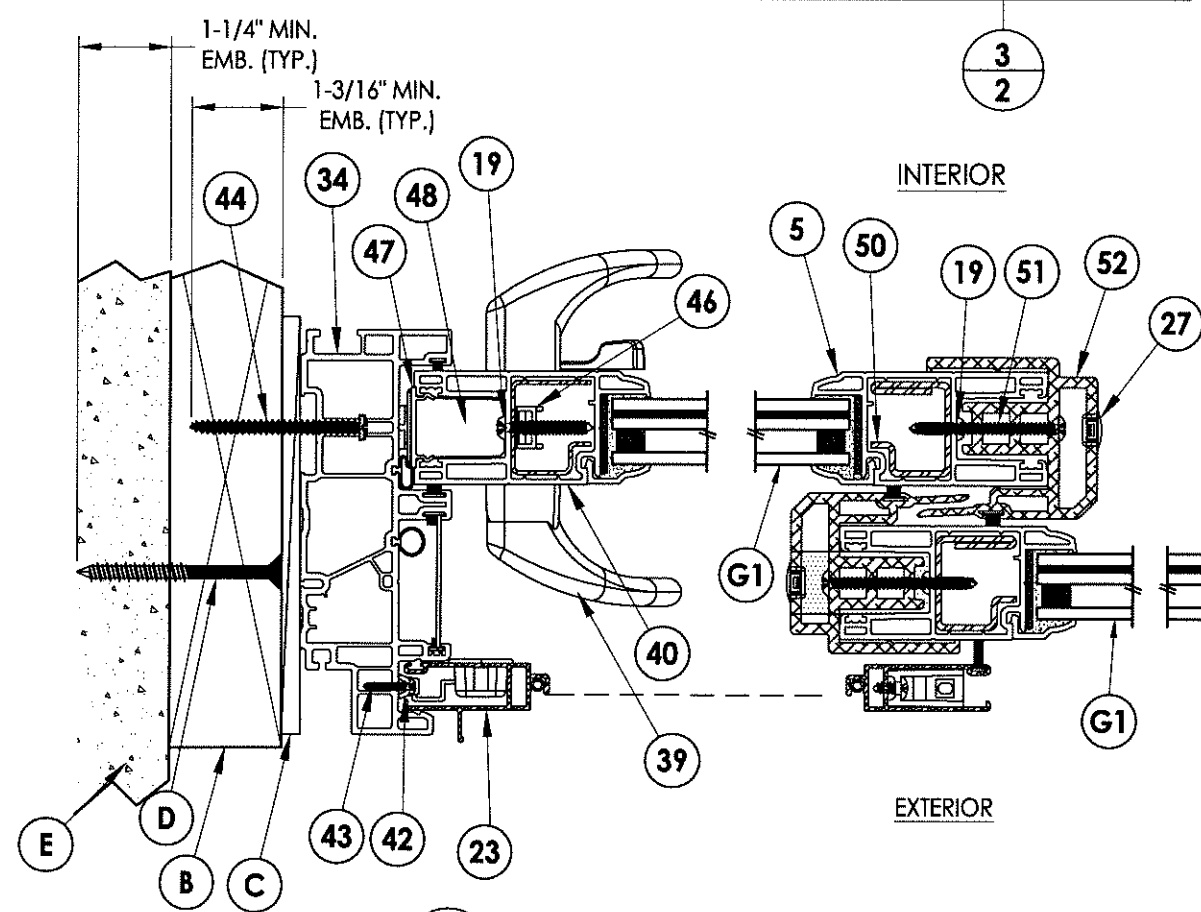
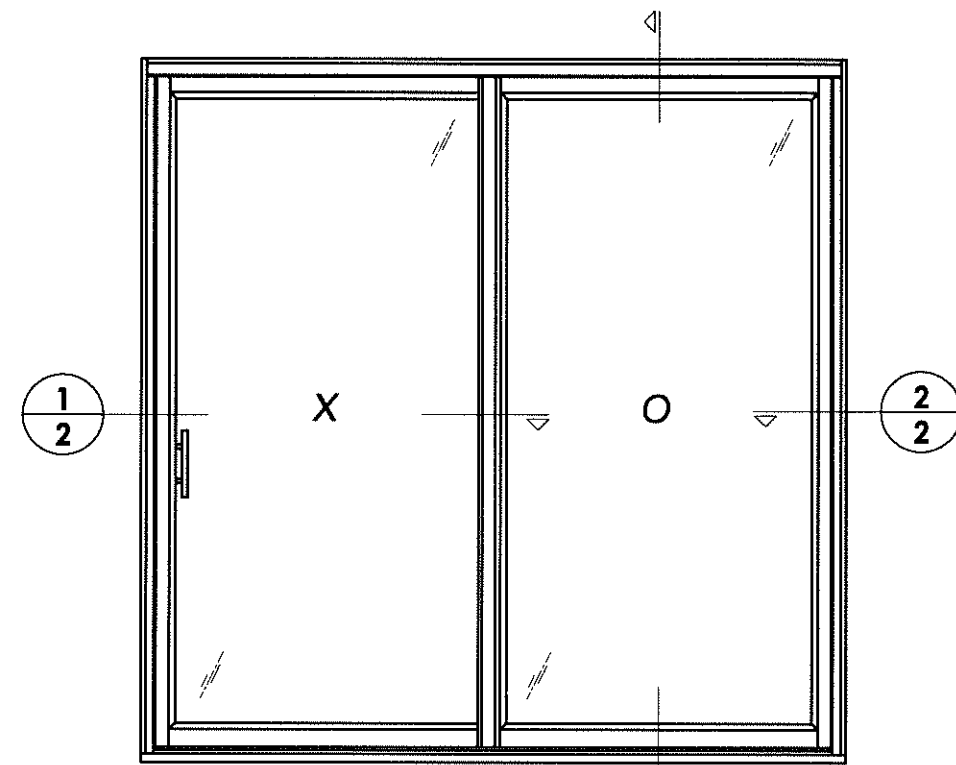

1 HORIZONTAL CROSS SECTION
2 Shown w/ 2X Buck

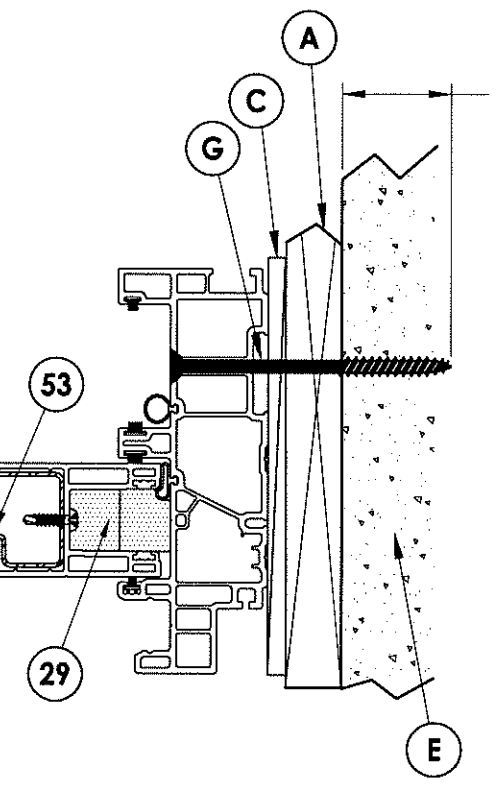

2 HORIZONTAL CROSS SECTION
2 Shown w/ 1X Buck

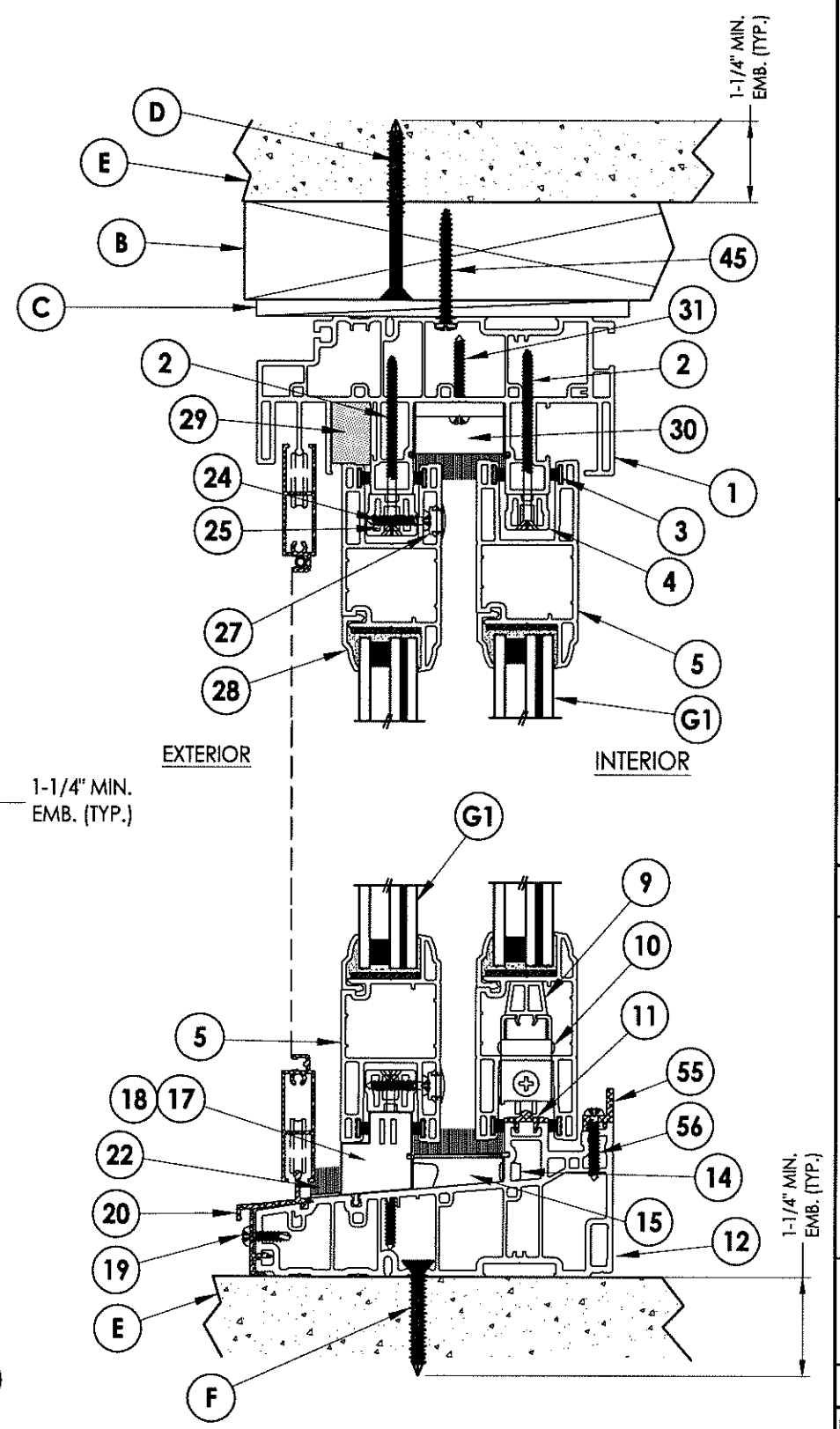

3 VERTICAL CROSS SECTION
2 Shown w/ 2X Buck at head & Direct to Masonry @ sill

| | |
|---|--|
| Documents Prepared By: RW BUILDING CONSULTANTS, INC. P.O. Box 230 Valrico FL 33595 Phone No.: 813.659.9197 Florida Board of Professional Engineers Certificate Of Authorization No. 9813 Lyndon F. Schmidt, P.E. No. 43409 | |
| PRODUCT: 8800 SERIES VINYL SLIDING PATIO DOORS | PART OR ASSEMBLY: HORIZONTAL & VERTICAL CROSS SECTIONS |
| NO. DATE | BY |
| REVISIONS | |
| DATE: 4/02/13 | SCALE: N.T.S. |
| DWG. BY: JK | CHK. BY: LFS |
| DRAWING NO.: FL-16216.3 | |
| SHEET 2 OF 5 | |

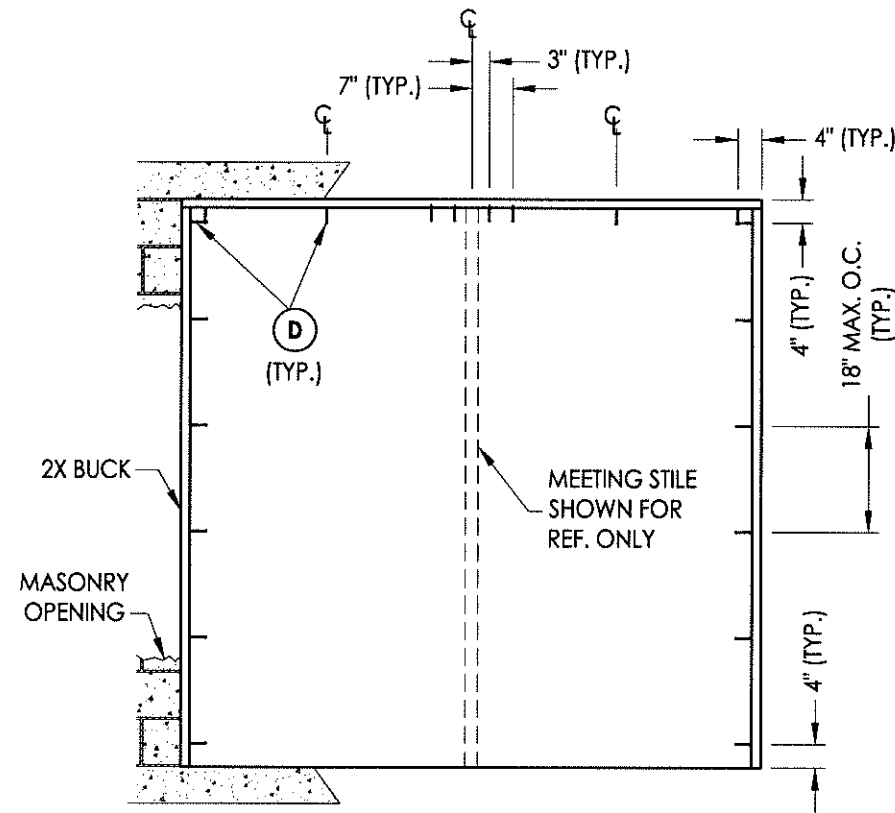

**BUCK ANCHORING
MASONRY**

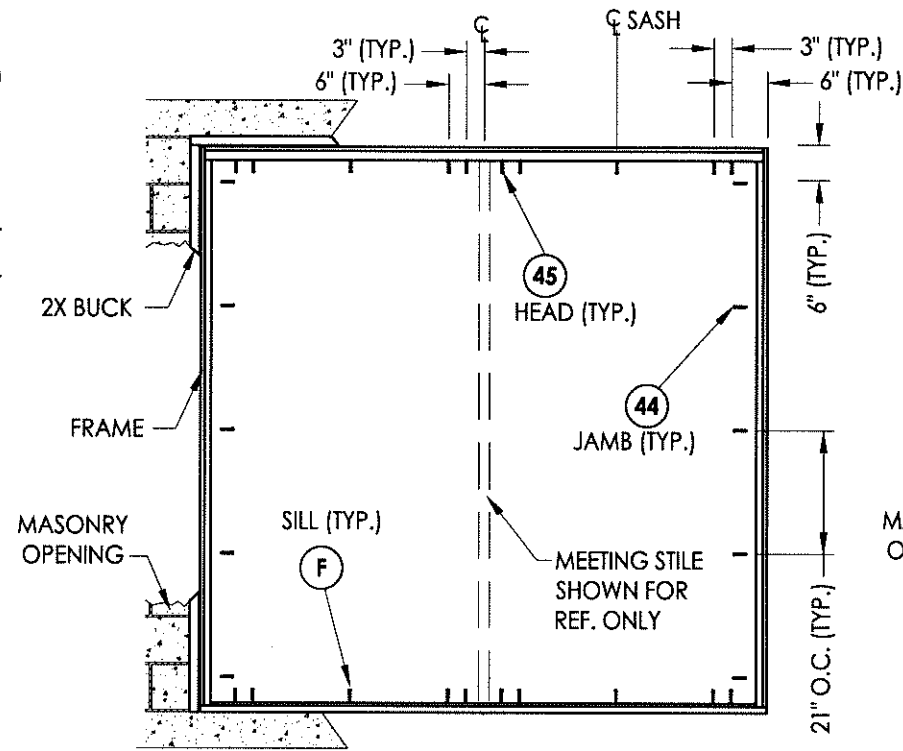

**FRAME ANCHORING
2X**

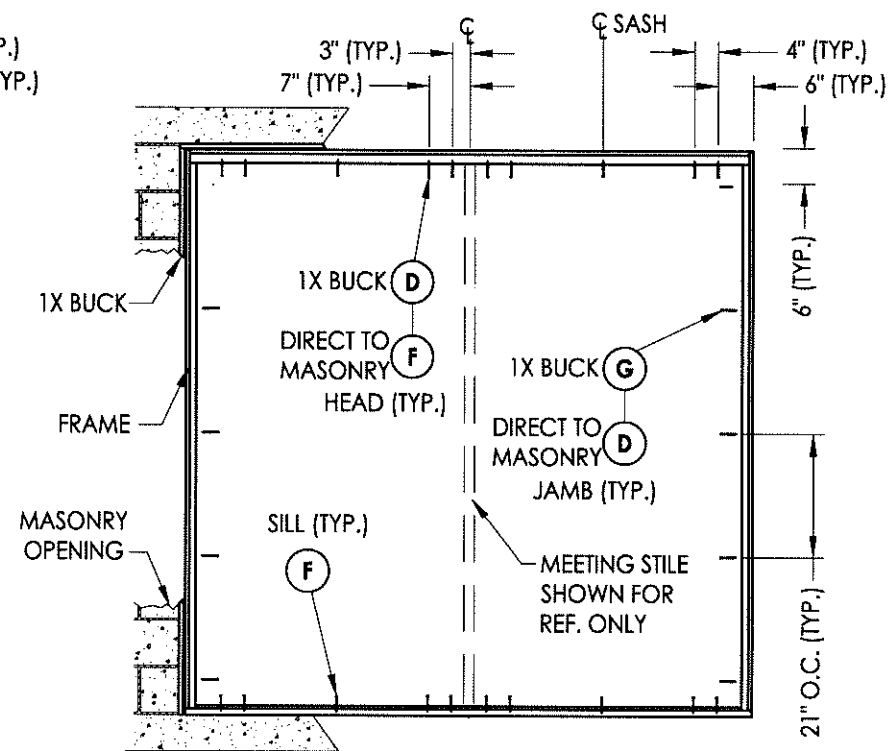

**FRAME ANCHORING
1X Buck, Direct to Masonry**

CONCRETE ANCHOR NOTES:

1. Substitution of equal concrete anchors from a different supplier may have different edge distance and center distance requirements.
2. Concrete anchor locations at the corners may be adjusted to maintain the min. edge distance to mortar joints. Concrete anchor locations noted as "MAX. ON CENTER" must be adjusted to maintain the min. edge distance to mortar joints, additional concrete anchors may be required to ensure the "MAX. ON CENTER" dimension are not exceeded.
3. Concrete anchor table:

| ANCHOR TYPE | ANCHOR SIZE | MIN. EMBEDMENT | MIN. CLEARANCE TO MASONRY EDGE | MIN. CLEARANCE TO ADJACENT ANCHOR |
|-------------|-------------|----------------|--------------------------------|-----------------------------------|
| ITW | 1/4" | 1-1/4" | 2-1/2" | 3" |
| ELCO | 1/4" | 1-1/4" | 1" | 4" |

Documents Prepared By:
RW BUILDING CONSULTANTS, INC.
 P.O. Box 230 Valrico FL 33595
 Phone No.: 813.659.9197
 Florida Board of Professional Engineers
 Certificate Of Authorization No. 9813
 Lyndon F. Schmidt, P.E. No. 43409

PRODUCT: 8800 SERIES VINYL SLIDING PATIO DOORS
 PART OR ASSEMBLY: BUCK & FRAME ANCHORING

| NO. | DATE | BY |
|-----|------|----|
| | | |
| | | |
| | | |
| | | |

DATE: 4/02/13
 SCALE: N.T.S.
 DWG. BY: JK
 CHK. BY: LFS
 DRAWING NO.: FL-16216.3
 SHEET 3 OF 5

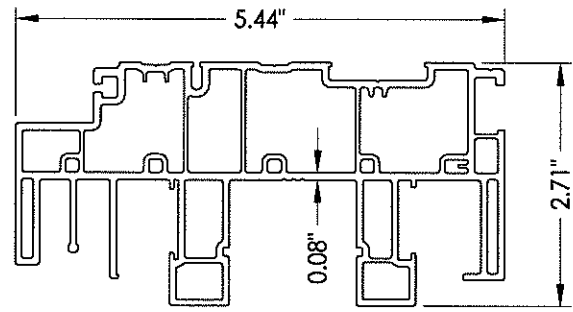

1 FRAME HEAD

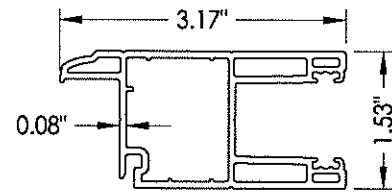

5 STILE, RAIL

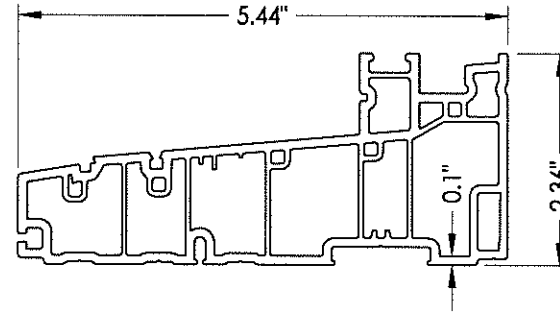

12 FRAME SILL

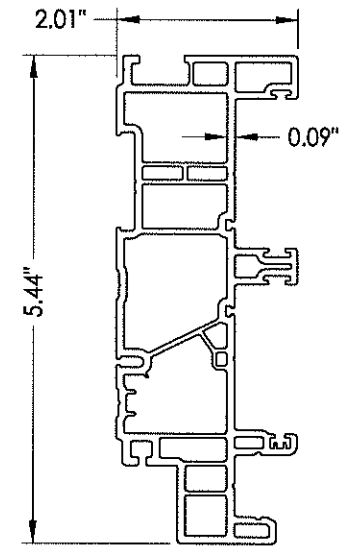

34 FRAME JAMB

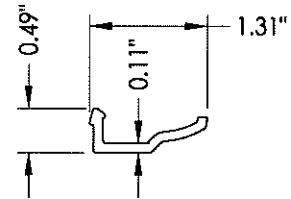

28 GLAZING BEAD

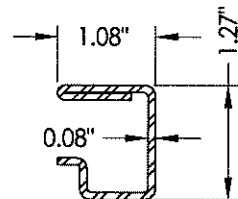

50 REINFORCEMENT Meeting rail

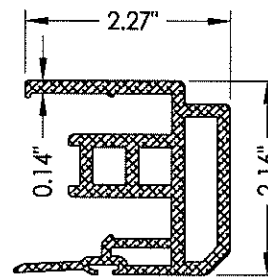

52 INTERLOCK

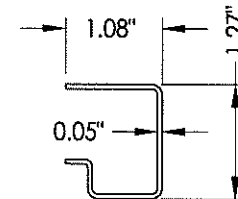

53 REINFORCEMENT Stile

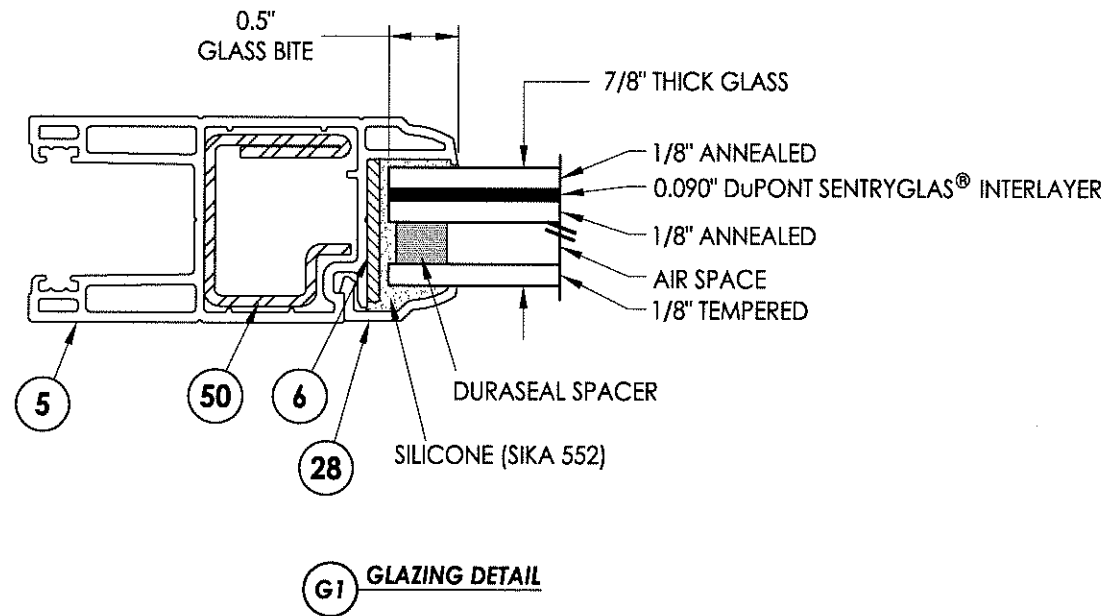

G1 GLAZING DETAIL

Documents Prepared By:

RW BUILDING CONSULTANTS, INC.
 P.O. Box 230 Valrico FL 33595
 Phone No.: 813.659.9197
 Florida Board of Professional Engineers
 Certificate Of Authorization No. 9813
Lyndon F. Schmidt 4-30-13
 Lyndon F. Schmidt, P.E. No. 43409

PRODUCT:
 8800 SERIES VINYL
 SLIDING PATIO DOORS

PART OR ASSEMBLY:
 GLAZING DETAILS &
 COMPONENTS

| NO. | DATE | BY |
|-----|------|----|
| | | |
| | | |
| | | |
| | | |

DATE: 4/02/13
 SCALE: N.T.S.
 DWG. BY: JK
 CHK. BY: LFS
 DRAWING NO.:
 FL-16216.3

SHEET 4 OF 5

| BILL OF MATERIALS | | |
|-------------------|--|----------|
| ITEM # | DESCRIPTION | MATERIAL |
| A | 1X BUCK SG >= 0.55 | WOOD |
| B | 2X BUCK SG >= 0.55 | WOOD |
| C | 1/4" MAX. SHIM SPACE | - |
| D | 1/4" X 2-3/4" ELCO OR ITW CONCRETE SCREW | STEEL |
| E | MASONRY - 3,192 PSI MIN. CONCRETE CONFORMING TO ACI 301 OR HOLLOW BLOCK CONFORMING TO ASTM C90 | CONCRETE |
| F | 1/4" X 1-3/4" ELCO OR ITW CONCRETE SCREW | STEEL |
| G | 1/4" X 3-3/4" ELCO OR ITW CONCRETE SCREW | STEEL |
| H | #10 X 5/8" FH SMS | STEEL |
| 1 | FRAME HEAD* | PVC |
| 2 | #8 x 2-3/4" FH QUADREX WOOD SCREW | STEEL |
| 3 | WEATHERSTRIP (SCHLEGEL #HF-7522-270) | - |
| 4 | HEAD TRACK* | PVC |
| 5 | STILE & RAIL* | PVC |
| 6 | SETTING BLOCK | - |
| 9 | SHIM | - |
| 10 | TANDEM WHEEL | NYLON |
| 11 | ROLLING RAIL | ALUM |
| 12 | SILL* | PVC |
| 13 | SILL DUST COVER* | PVC |
| 14 | SILL PLUG | NYLON |
| 15 | SILL WEATHERSEAL | - |
| 17 | LEFT CAP FOR SILL ADAPTER* | PVC |
| 18 | RIGHT CAP FOR SILL ADAPTER* | PVC |
| 19 | #8 X 5/8" PAN HEAD, SQUARE, SELF-DRILLING SCREW | STEEL |
| 20 | OUTSIDE SILL CLADDING | ALUM |
| 22 | INSECT STOP | - |
| 23 | SCREEN | - |
| 24 | #8 X 7/8" PAN HEAD, QUADREX, SCREW | STEEL |
| 25 | FIXED PANEL ANCHOR BLOCK* | PVC |
| 26 | ANCHOR STRAP | STEEL |
| 27 | SCREW CAP | NYLON |
| 28 | GLAZING BEAD* | PVC |

* THE APPROVED WHITE RIGID PVC EXTERIOR EXTRUSIONS FOR WINDOWS ARE TO BE PRODUCED BY EXTRUDERS LICENSEES IN "AAMA CERTIFICATION PROGRAMS FOR RIGID PVC EXTRUSIONS".

| | | |
|----|---|-------|
| 29 | FOAM PLUG | - |
| 30 | HEAD WEATHERSEAL | - |
| 31 | #8 X 1-1/4" PAN HEAD, QUADREX, SCREW | STEEL |
| 32 | SASH STOPPER | EPDM |
| 33 | WEATHERSTRIP | - |
| 34 | FRAME JAMB* | PVC |
| 35 | WEATHERSTRIP | - |
| 39 | HANDLE KIT | STEEL |
| 40 | OPERATING PANEL SIDE STILE* | PVC |
| 42 | KEEPER FOR SCREEN | - |
| 43 | #4 X 5/8" PAN HEAD QUADREX SCREW | STEEL |
| 44 | #10 X 2-1/2" PPH SCREW | STEEL |
| 45 | #10 X 1-3/4" PPH SCREW | STEEL |
| 46 | STAINLESS STEEL DOUBLE POINT MORTISE LOCK KIT | STEEL |
| 47 | SASH COVERING CAP* | PVC |
| 48 | LOCK PLUG* | PVC |
| 50 | STILE REINFORCEMENT | STEEL |
| 51 | #8 X 2" TRUSS HEAD QUADREX SCREW | STEEL |
| 52 | INTERLOCK | ALUM |
| 53 | STILE REINFORCEMENT | STEEL |
| 54 | Q-LON WEATHERSTRIP (SCHLEGEL NO. QEZ 345) | - |
| 55 | WATER BAR | ALUM |
| 56 | #8 X 1" PPH SMS | SS |

Documents Prepared By:
RW BUILDING CONSULTANTS, INC.
 P.O. Box 230 Valrico FL 33595
 Phone No.: 813.659.9197
 Florida Board of Professional Engineers
 Certificate Of Authorization No. 9813
LFS
 Lyndon F. Schmidt, P.E. No. 43409

PRODUCT: 8800 SERIES VINYL SLIDING PATIO DOORS
 PART OR ASSEMBLY: BILL OF MATERIALS

| NO. | DATE | BY | REVISIONS |
|-----|------|----|-----------|
| | | | |
| | | | |
| | | | |
| | | | |
| | | | |

DATE: 4/02/13
 SCALE: N.T.S.
 DWG. BY: JK
 CHK. BY: LFS
 DRAWING NO.: FL-16216.3
 SHEET 5 OF 5