

WINCORE™

WINDOWS & DOORS

250 Staunton Turnpike, Parkersburg, WV 26104

8800 Series Vinyl Horizontal Sliding Window "IMPACT"

GENERAL NOTES

1. This product has been evaluated and is in compliance with the 2010 Florida Building Code (FBC) structural requirements excluding the "High Velocity Hurricane Zone" (HVHZ).
2. Product anchors shall be as listed and spaced as shown on details. Anchor embedment to base material shall be beyond wall dressing or stucco.
3. When used in areas requiring wind borne debris protection this product complies with Section 1609.1.2 of the FBC and does not require an impact resistant covering. This product meets missile level "D" and includes Wind Zone 4 as defined in ASTM E 1996 and Section 1609.1.2.4 of the FBC.
4. For 2x stud framing construction, anchoring of these units shall be the same as that shown for 2x buck masonry construction.
5. Site conditions that deviate from the details of this drawing require further engineering analysis by a licensed engineer or registered architect.

TABLE OF CONTENTS

SHEET#	DESCRIPTION
1	Typical elevations, design pressures and general notes
2	Horizontal cross sections
3	Vertical cross sections
4	Buck and frame anchoring
5	Components
6	Bill of materials & glazing details

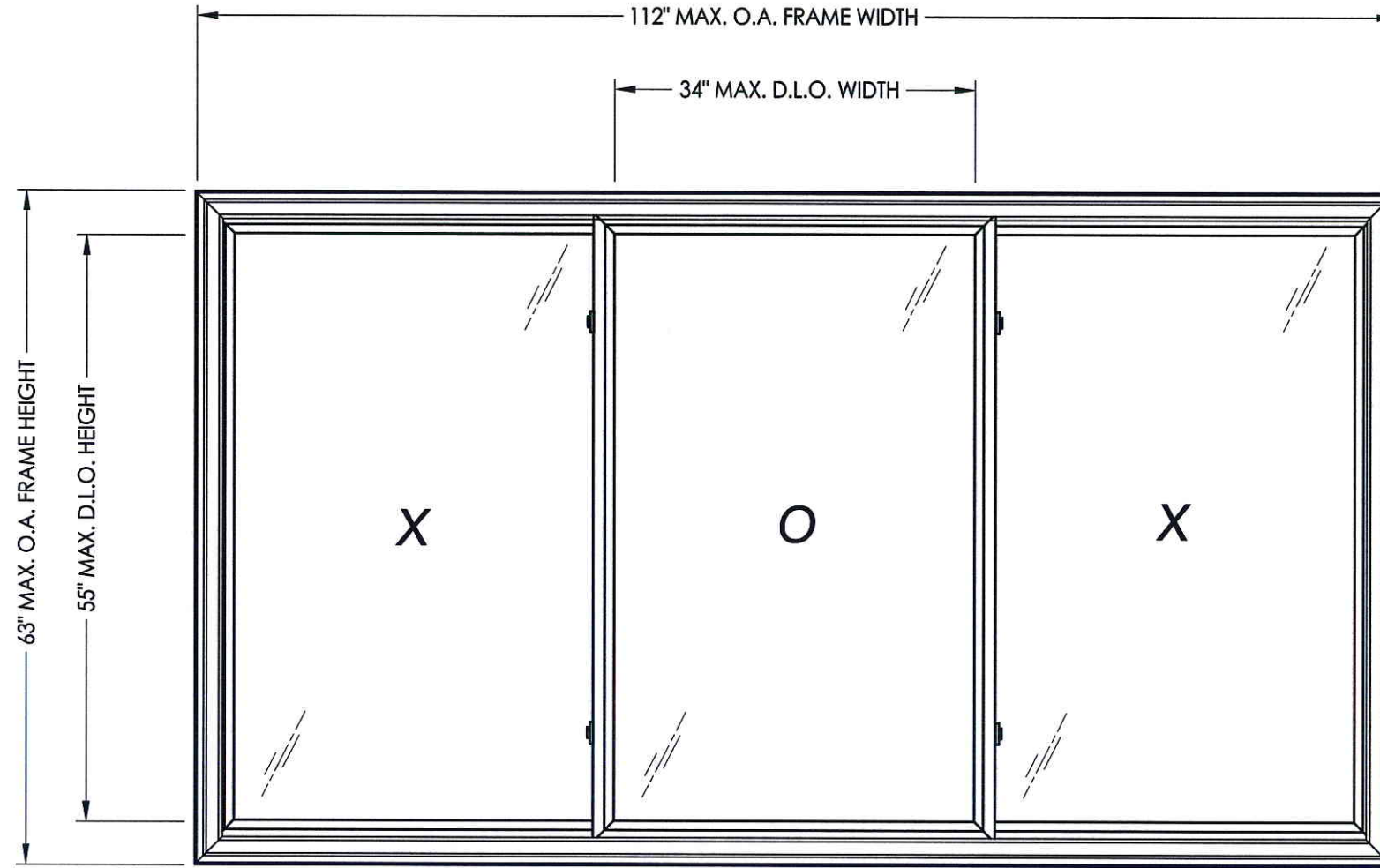

XOX SHOWN
XXX ALSO APPROVED

MAX. FRAME DIMENSION	MAX. D.L.O. DIMENSION	GLASS TYPE	DESIGN PRESSURE (PSF)	
			POSITIVE	NEGATIVE
110.0" X 62.0"	33.0" X 54.0"	G1	+55.0	-55.0

Documents Prepared By:

RW BUILDING CONSULTANTS, INC.
P.O. Box 230 Vairico FL 33595
Phone No.: 813.659.9197
Florida Board of Professional Engineers
Certificate Of Authorization No. 9813
LFS 4.22.13
Lyndon F. Schmidt, P.E. No. 43409

PRODUCT: 8800 SERIES

PART OR ASSEMBLY:
TYPICAL ELEVATION, DESIGN PRESSURES & GENERAL NOTES

NO.	DATE	UPDATE	FRAME SIZE/DP/GLZ	BY	REVISIONS
1	4/04/13			LFS	

DATE: 12/05/12

SCALE: N.T.S.

DWG. BY: JK

CHK. BY: LFS

DRAWING NO.:
FL-16092.6

SHEET 1 OF 6

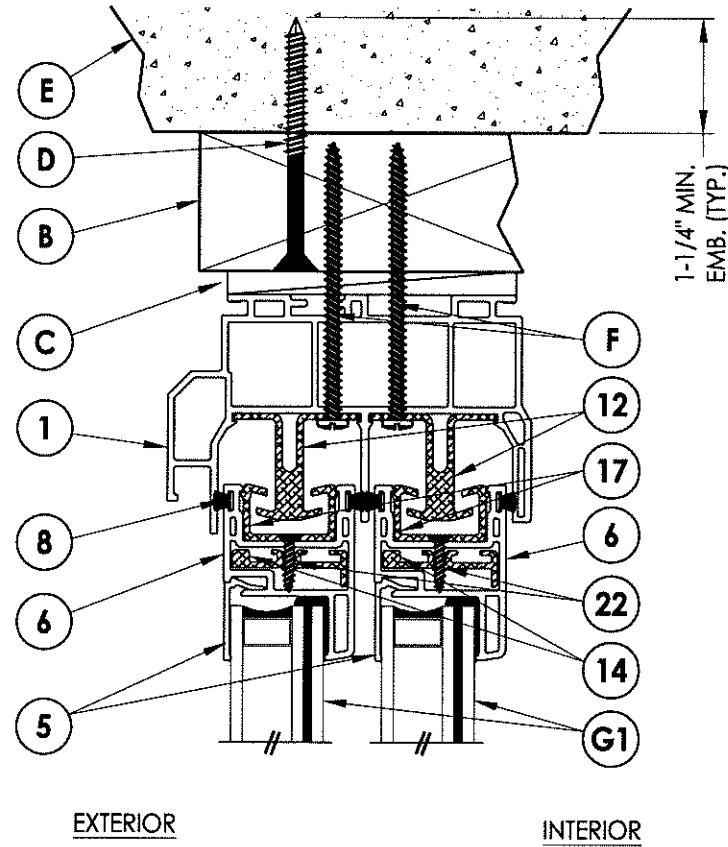

EXTERIOR INTERIOR

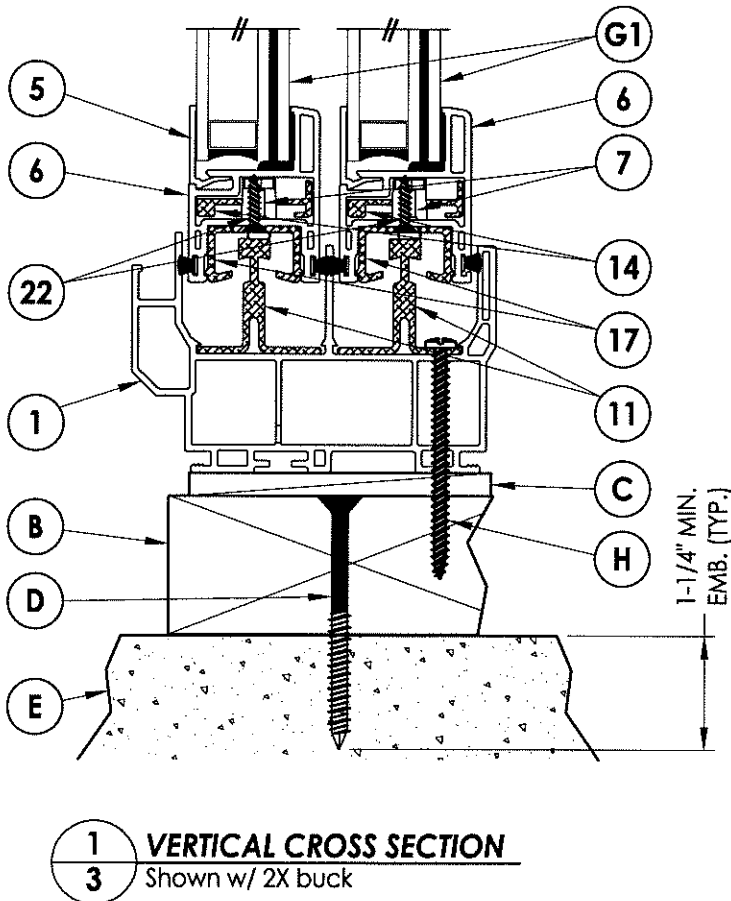

1 VERTICAL CROSS SECTION
3 Shown w/ 2X buck

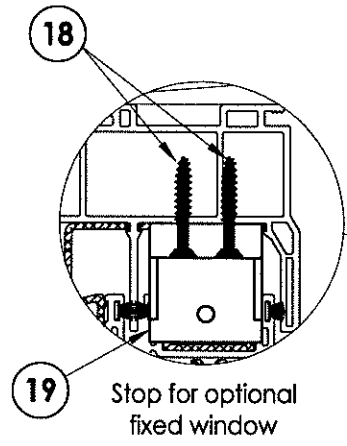

18
19 Stop for optional fixed window

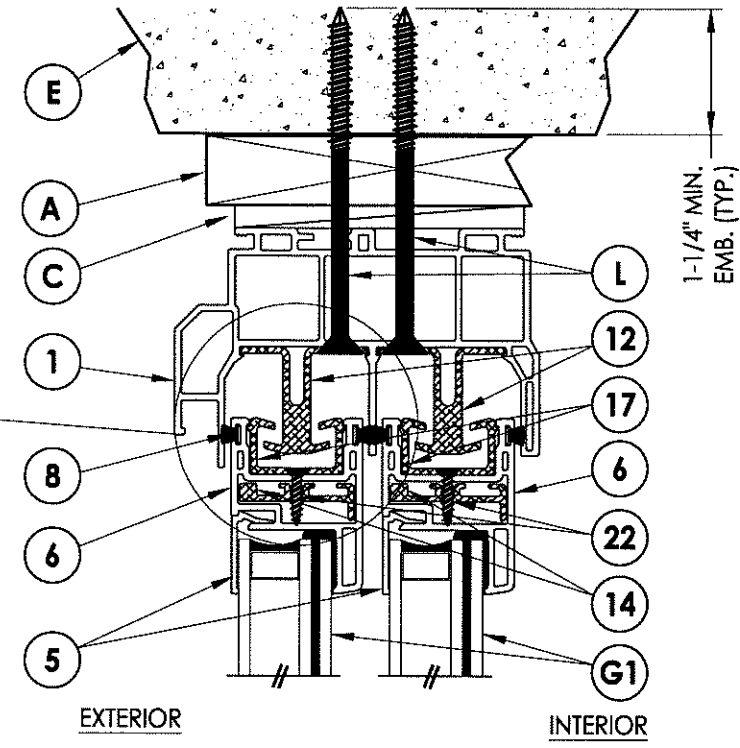

EXTERIOR INTERIOR

2 VERTICAL CROSS SECTION
3 Shown w/ 1X buck

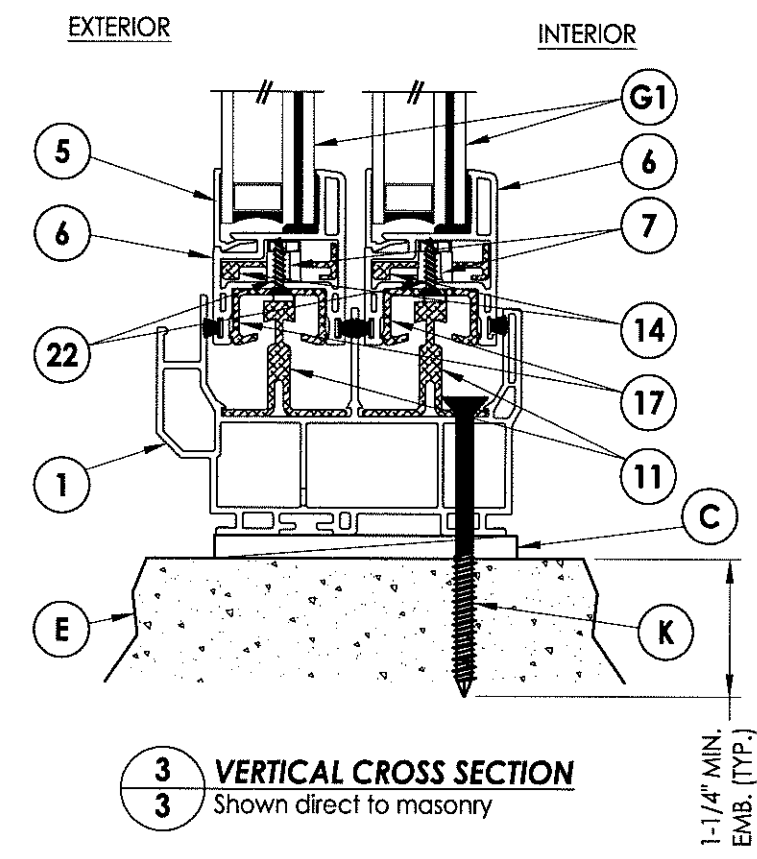

3 VERTICAL CROSS SECTION
3 Shown direct to masonry

Documents Prepared By:		BUILDING CONSULTANTS, INC. P.O. Box 230 Valrico FL 33595 Phone No.: 813.659.9197 Florida Board of Professional Engineers Certificate Of Authorization No. 9813 <i>LFS</i> 4.22.13	
PRODUCT:	8800 SERIES	PART OR ASSEMBLY:	VERTICAL CROSS SECTIONS
		NO.	DATE
		1	4/04/13
			ADD COSMETIC FLANGES
			REVISIONS
			LFS BY
DATE:	12/05/12		
SCALE:	N.T.S.		
DWG. BY:	JK		
CHK. BY:	LFS		
DRAWING NO.:	FL-16092.6		
SHEET	3	OF	6

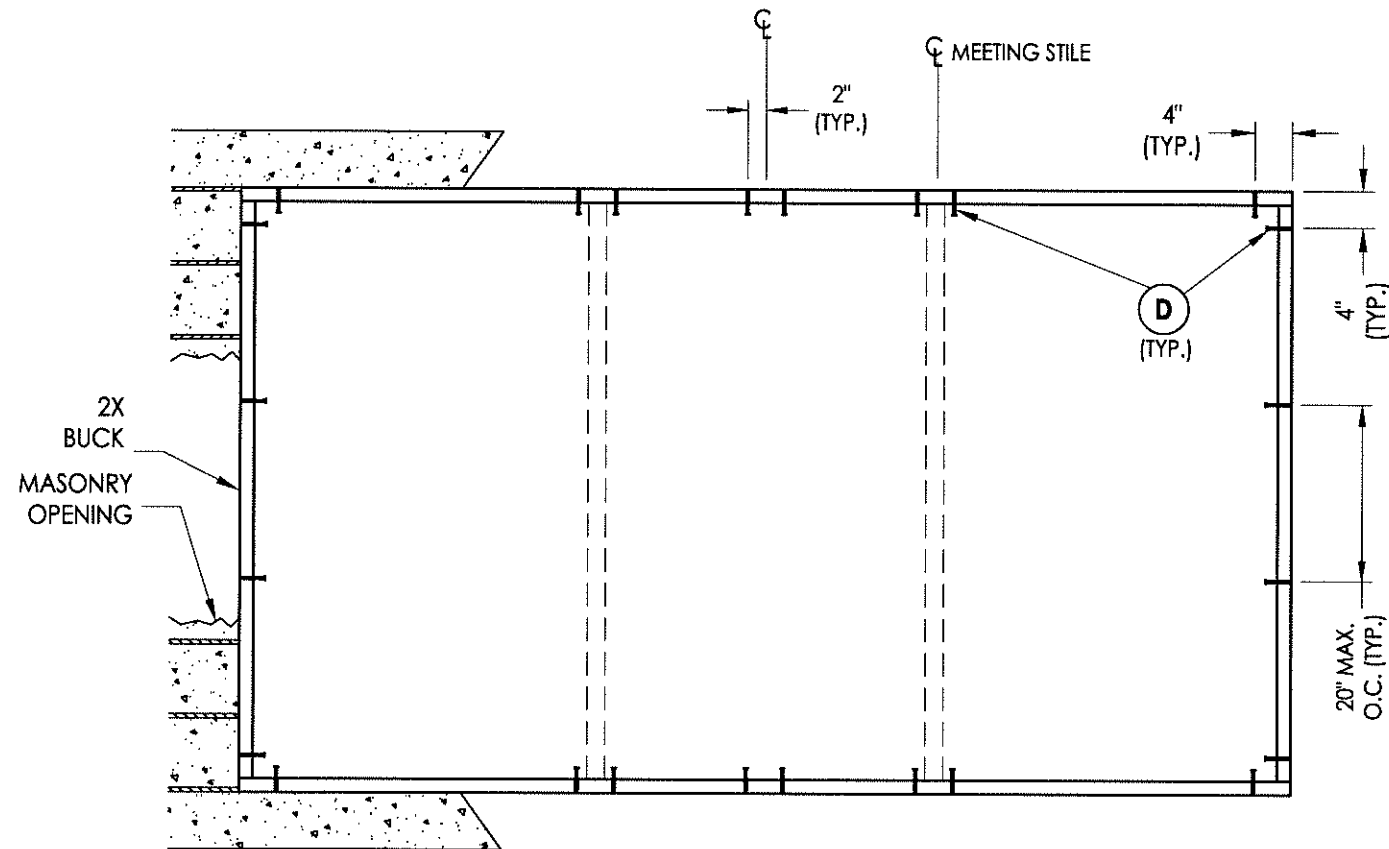

BUCK ANCHORING

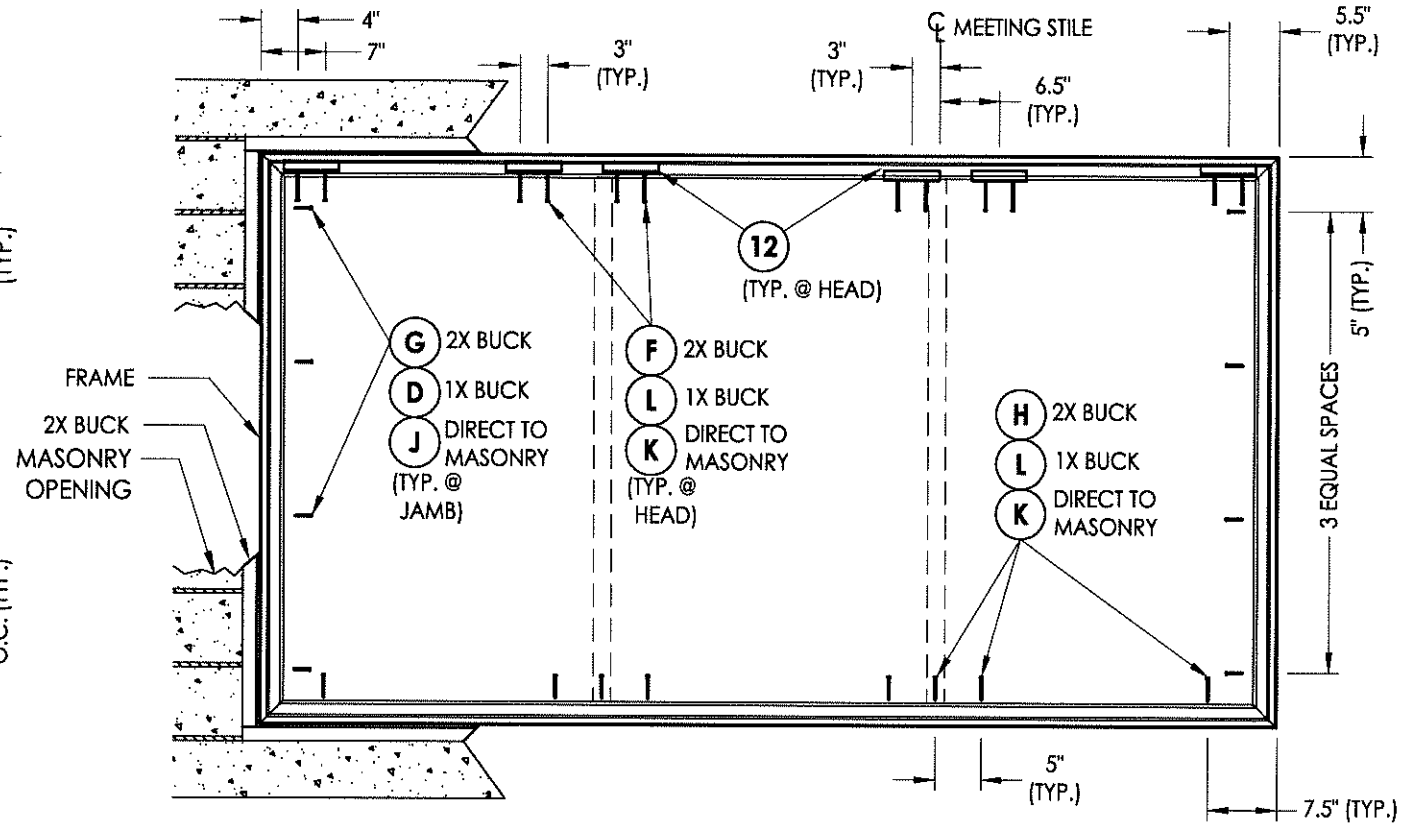

FRAME ANCHORING

CONCRETE ANCHOR NOTES:

1. Substitution of equal concrete anchors from a different supplier may have different edge distance and center distance requirements.
2. Concrete anchor locations at the corners may be adjusted to maintain the min. edge distance to mortar joints. If concrete anchor locations noted as "MAX. ON CENTER" must be adjusted to maintain the min. edge distance to mortar joints, additional concrete anchors may be required to ensure the "MAX. ON CENTER" dimensions are not exceeded.
3. Concrete anchor table:

ANCHOR TYPE	ANCHOR SIZE	MIN. EMBEDMENT	MIN. CLEARANCE TO MASONRY EDGE	MIN. CLEARANCE TO ADJACENT ANCHOR
ITW	1/4"	1-1/4"	2-1/2"	3"
ELCO	1/4"	1-1/4"	1"	4"

Documents Prepared By:

RW BUILDING CONSULTANTS, INC.
 P.O. Box 230 Valrico FL, 33595
 Phone No.: 813.659.9197
 Florida Board of Professional Engineers
 Certificate Of Authorization No. 9813
 17524.22.12
 Lyndon F. Schmidt, P.E. No. 43409

PRODUCT: 8800 SERIES

PART OR ASSEMBLY:
 BUCK AND
 FRAME ANCHORING

NO.	DATE	ADD COSMETIC FLANGES	BY
1	4/04/13		LFS

REVISIONS

DATE: 12/05/12

SCALE: N.T.S.

DWG. BY: JK

CHK. BY: LFS

DRAWING NO.:
 FL-16092.6

SHEET 4 OF 6

BILL OF MATERIALS		
ITEM #	DESCRIPTION	MATERIAL
A	1X BUCK SG >= 0.42	WOOD
B	2X BUCK SG >= 0.42	WOOD
C	1/4" MAX. SHIM SPACE	-
D	1/4" X 2-3/4" PFH ELCO OR ITW CONCRETE SCREW	STEEL
E	MASONRY - 3,192 PSI MIN. CONCRETE CONFORMING TO ACI 301 OR HOLLOW BLOCK CONFORMING TO ASTM C90	CONCRETE
F	#10 X 3" PPH WOOD SCREW	STEEL
G	#10 X 1-3/4" PPH WOOD SCREW	STEEL
H	#10 X 2-1/2" PPH WOOD SCREW	STEEL
J	1/4" X 2-1/4" ITW CONCRETE SCREW	STEEL
K	1/4" X 3-1/4" ITW CONCRETE SCREW	STEEL
L	1/4" X 3-3/4" ITW CONCRETE SCREW	STEEL
1	FRAME*	PVC
2	SLIDER PULL STILE*	PVC
3	LOCK STILE*	PVC
4	KEEPER STILE*	PVC
5	GLAZING BEAD*	PVC
6	SLIDER COMMON RAIL*	PVC
7	BALL BEARING ROLLER	-
8	WEATHERSTRIP (0.230")	-
9	WEATHERSTRIP (0.380")	-
11	SILL TRACK	ALUM
12	HEAD TRACK	ALUM
14	SLIDE RAIL REINFORCEMENT	ALUM
15	REINFORCEMENT	ALUM
16	REINFORCEMENT	ALUM
17	SLIDER SASH RETAINING CLIP	ALUM
18	#8 X 1" PFH SMS	STEEL
19	FLANKER STOP	NYLON
22	#8 X 5/8" (#6 head) PFH SMS	STEEL

* THE APPROVED WHITE RIGID PVC EXTERIOR EXTRUSIONS FOR WINDOWS ARE TO BE PRODUCED BY EXTRUDERS LICENSEES IN "AAMA CERTIFICATION PROGRAMS FOR RIGID PVC EXTRUSIONS".

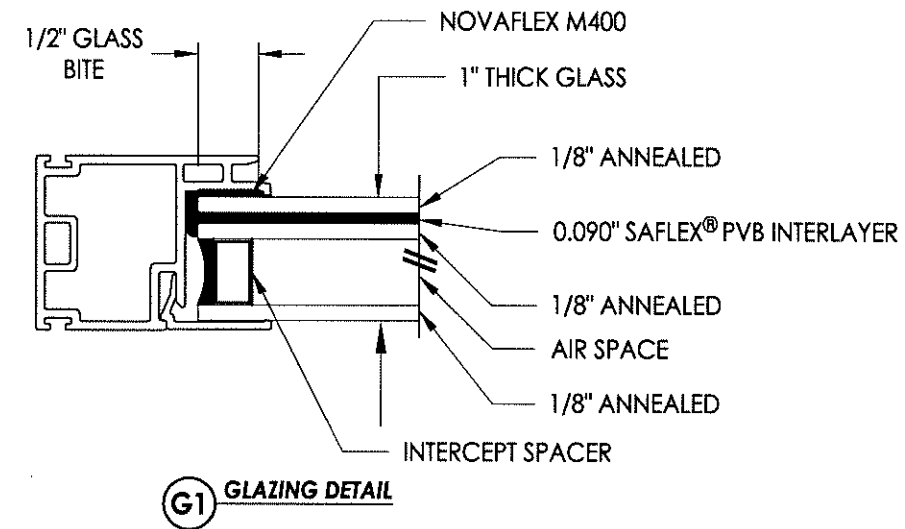

Documents Prepared By:

RW BUILDING CONSULTANTS, INC.
P.O. Box 230 Valrico FL 33595
Phone No.: 813.659.9197
Florida Board of Professional Engineers
Certificate Of Authorization No. 9813
4/21/13
Lyndon F. Schmidt, P.E. No. 43409

PRODUCT: 8800 SERIES

PART OR ASSEMBLY:
BILL OF MATERIALS
& GLAZING DETAILS

NO.	DATE	ADD. COSMETIC FLANGES	LFS	BY
1	4/04/13			

REVISIONS

DATE: 12/05/12

SCALE: N.T.S.

DWG. BY: JK

CHK. BY: LFS

DRAWING NO.:
FL-16092.6

SHEET 6 OF 6