

REVISIONS			
REV	DESCRIPTION	DATE	APPROVED
A	ADDED FRAME MATERIAL	2/28/11	R.L.

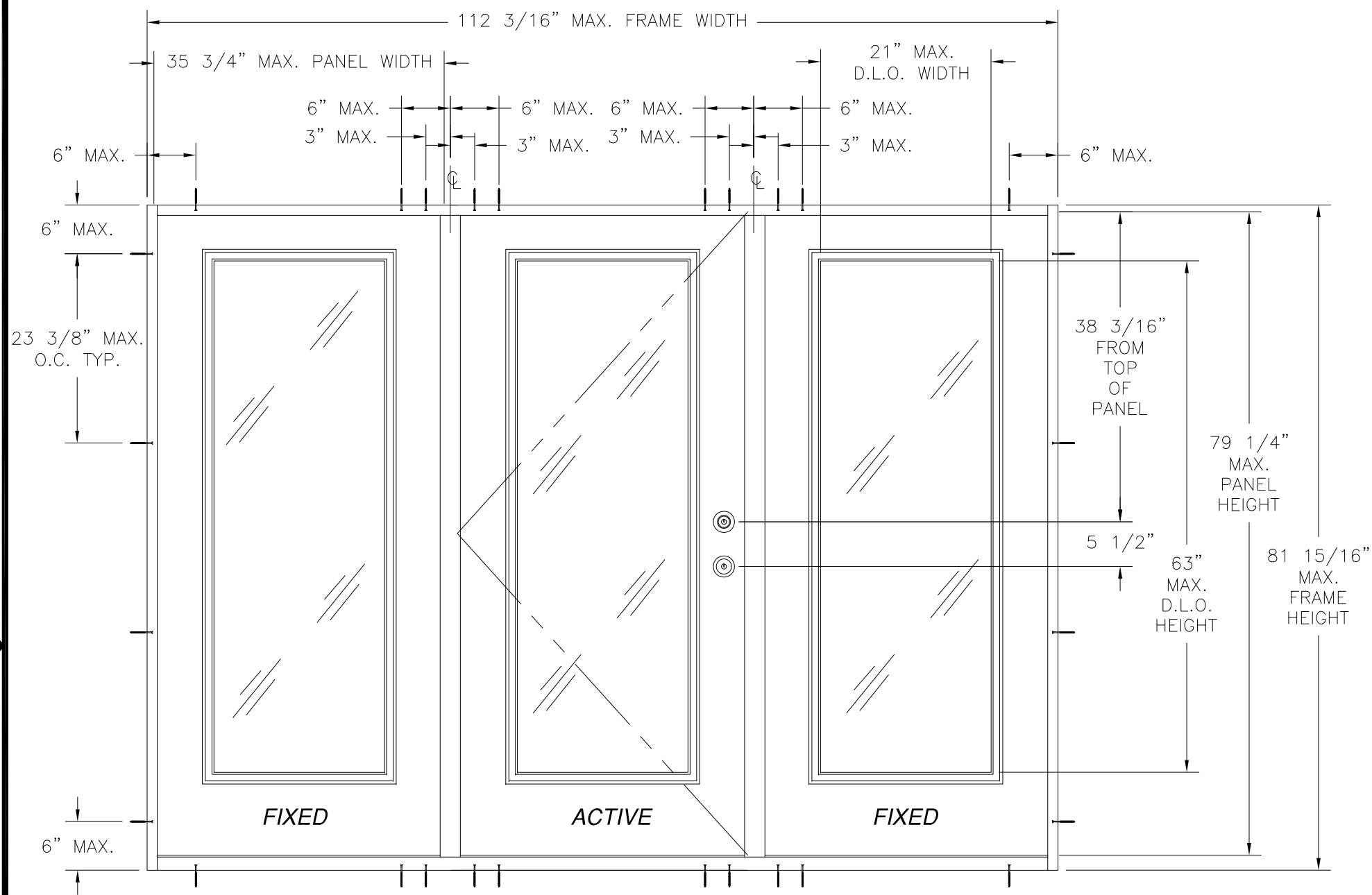

NOTES:

- 1) THE PRODUCT SHOWN HEREIN IS DESIGNED AND MANUFACTURED TO COMPLY WITH REQUIREMENTS OF FLORIDA BUILDING CODE.
- 2) WOOD FRAMING AND MASONRY OPENING TO BE DESIGNED AND ANCHORED TO PROPERLY TRANSFER ALL LOADS TO STRUCTURE. WOOD FRAMING AND MASONRY OPENING IS THE RESPONSIBILITY OF THE ARCHITECT OR ENGINEER OF RECORD.
- 3) 1X BUCK OVER MASONRY/CONCRETE IS OPTIONAL. WHERE 1X BUCK IS NOT USED DISSIMILAR MATERIALS MUST BE SEPARATED WITH APPROVED COATING OR MEMBRANE. SELECTION OF COATING OR MEMBRANE IS THE RESPONSIBILITY OF THE ARCHITECT OR ENGINEER OF RECORD.
- 4) APPROVED IMPACT PROTECTIVE SYSTEM IS REQUIRED FOR THIS PRODUCT IN WIND BORNE DEBRIS REGIONS.
- 5) UNITS MUST BE GLAZED PER ASTM E1300.
- 6) ALLOWABLE STRESS INCREASE OF 1/3 WAS NOT USED IN THE DESIGN OF THE PRODUCT SHOWN HEREIN. WIND LOAD DURATION FACTOR Cd=1.6 WAS USED FOR WOOD ANCHOR CALCULATIONS.
- 7) SHIM AS REQUIRED AT EACH INSTALLATION ANCHOR WITH LOAD BEARING SHIM. SHIM WHERE SPACE OF 1/16" OR GREATER OCCURS. MAXIMUM ALLOWABLE SHIM STACK TO BE 1/4".
- 8) FOR ANCHORING INTO 2X BUCK OR WOOD FRAMING AT HEAD AND JAMBS USE #8 WOOD SCREW OF SUFFICIENT LENGTH TO ACHIEVE A 1 3/16" MINIMUM EMBEDMENT INTO SUBSTRATE. AT SILL USE #10 WOOD SCREW OF SUFFICIENT LENGTH TO ACHIEVE A 1 3/8" MINIMUM EMBEDMENT INTO SUBSTRATE LOCATE ANCHORS AS SHOWN IN ANCHORING LAYOUT AND INSTALLATION DETAILS.
- 9) FOR ANCHORING INTO MASONRY/CONCRETE USE 3/16" ITW TAPCON OF SUFFICIENT LENGTH TO ACHIEVE A 1 1/4" MINIMUM EMBEDMENT INTO SUBSTRATE WITH 2 5/8" MINIMUM EDGE DISTANCE. LOCATE ANCHORS AS SHOWN IN ANCHORING LAYOUT AND INSTALLATION DETAILS.
- 10) ALL FASTENERS TO BE CORROSION RESISTANT.
- 11) INSTALLATION ANCHOR CAPACITIES FOR PRODUCTS HEREIN ARE BASED ON SUBSTRATE MATERIAL WITH THE FOLLOWING PROPERTIES:
 A. WOOD - G=0.42 MINIMUM SPECIFIC GRAVITY
 B. CONCRETE - 2,000PSI MINIMUM COMPRESSIVE STRENGTH.
 C. MASONRY - STRENGTH CONFORMANCE TO ASTM C-90, GRADE N, TYPE 1 (OR GREATER).
- 12) FRAME MATERIAL: WOOD WITH G .5 MINIMUM SPECIFIC GRAVITY OR COMPOSITE FRAME (PLAST PRO POLY FIBER).
- 13) DOOR PANEL MATERIAL: .075" THICK FIBERGLASS WITH PVC TOP AND BOTTOM RAILS AND LAMINATED WOOD STILES.

PLASTPRO INSERT GLAZED FIBERGLASS 6'8 IS OXO DOOR
EXTERIOR VIEW

DESIGN PRESSURE RATING	IMPACT RATING
+40.0 PSF -45.0 PSF	NONE

APPROVED CONFIGURATIONS: O, X, OX, XO, OXO
ANCHORING LAYOUT ABOVE APPLIES TO ALL APPROVED CONFIGURATIONS.

TABLE OF CONTENTS	
SHEET NO.	DESCRIPTION
1 - 4	ELEVATIONS, ANCHORING LAYOUTS AND NOTES
5 - 8	INSTALLATION DETAILS
9	APPROVED SILLS AND MULL DETAIL

WINCORE WINDOW COMPANY, LLC.
250 STAUNTON AVE.
PARKERSBURG, WV 26102

PLASTPRO INSERT GLAZED FIBERGLASS IS/OS
OXO DOOR - NON-IMPACT
6'8 IS ELEVATION, ANCHORING LAYOUT AND NOTES

DRAWN: TJH DWG NO. 08-01102 REV A

SCALE NTS DATE 09/03/10 SHEET 1 OF 9

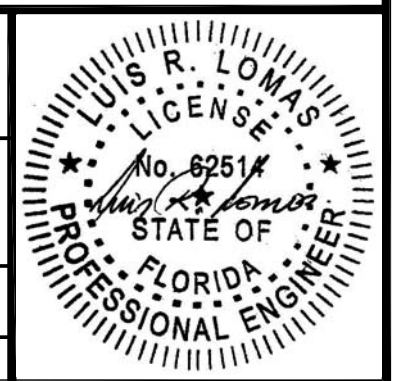

REVISIONS			
REV	DESCRIPTION	DATE	APPROVED
A	ADDED FRAME MATERIAL	2/28/11	R.L.

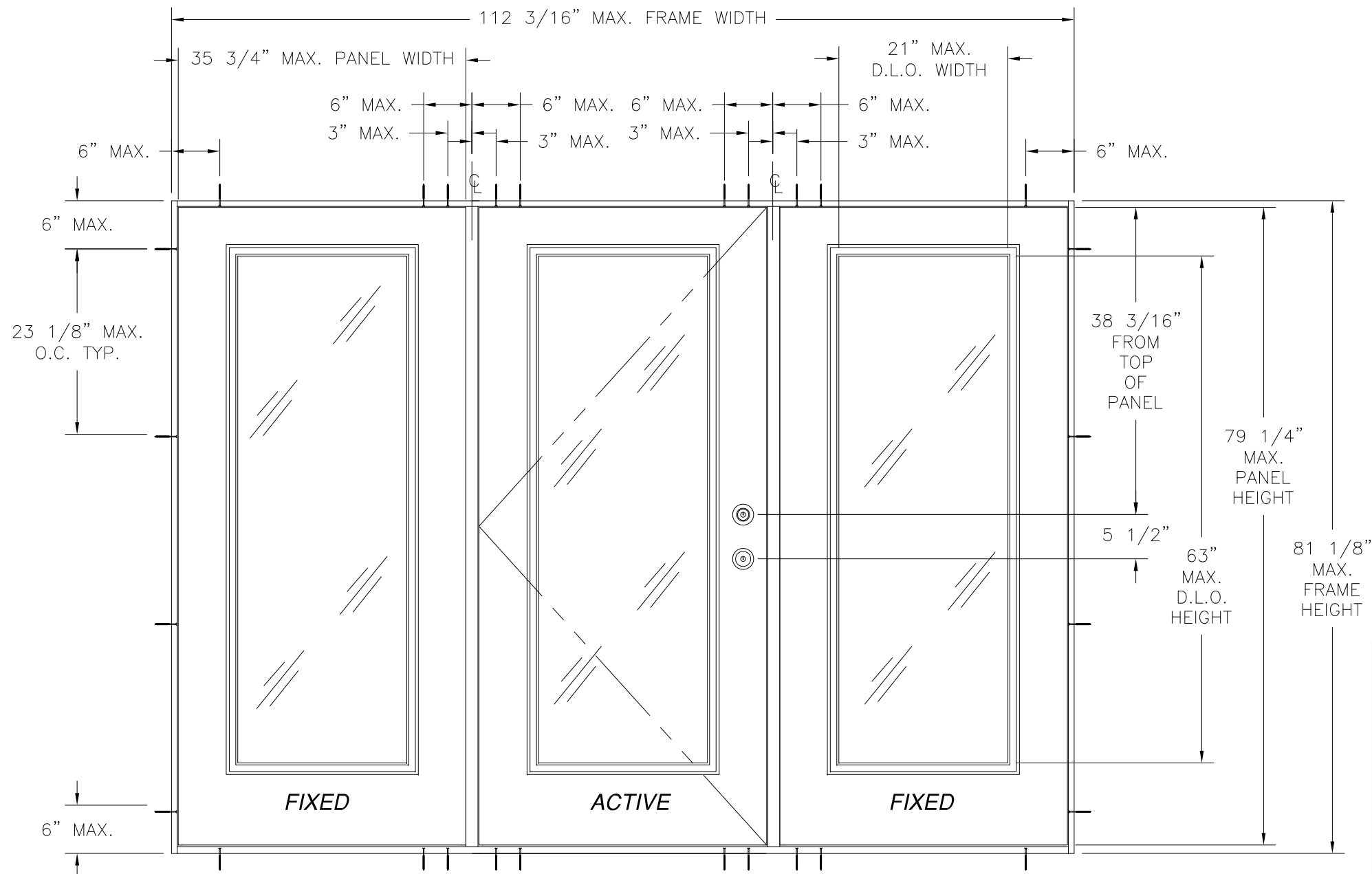

PLASTPRO INSERT GLAZED FIBERGLASS 6'8 OS OXO DOOR
EXTERIOR VIEW

DESIGN PRESSURE RATING	IMPACT RATING
+45.0 PSF -50.0 PSF	NONE

APPROVED CONFIGURATIONS: O, X, OX, XO, OXO
ANCHORING LAYOUT ABOVE APPLIES TO ALL APPROVED CONFIGURATIONS.

HARDWARE SCHEDULE	
A.	KEYED ENTRY LOCK GRADE 2 OR BETTER
B.	DEADBOLT GRADE 2 OR BETTER
C.	MULTI-POINT LOCKING HARDWARE BY TRILLENIUM
D.	4" x 4" BUTT TYPE HINGE (3 PER 6'8 DOORS).
E.	4" x 4" BUTT TYPE HINGE (4 PER 8'0 DOORS).
F.	INSWING AND OUTSWING SILLS BY ENDURA, SEE SHEET 9
G.	INSWING 4 3/8" FAT BOY MULL BY ENDURA
H.	OUTSWING 4 3/8" FAT BOY MULL BY ENDURA

WINCORE WINDOW COMPANY, LLC.
250 STAUNTON AVE.
PARKERSBURG, WV 26102

PLASTPRO INSERT GLAZED FIBERGLASS IS/OS
OXO DOOR - NON-IMPACT
6'8 OS ELEVATION AND ANCHORING LAYOUT

DRAWN: TJH	DWG NO. 08-01102	REV A
SCALE NTS	DATE 09/03/10	SHEET 2 OF 9

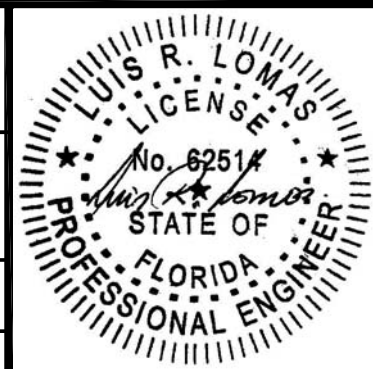

REVISIONS			
REV	DESCRIPTION	DATE	APPROVED
A	ADDED FRAME MATERIAL	2/28/11	R.L.

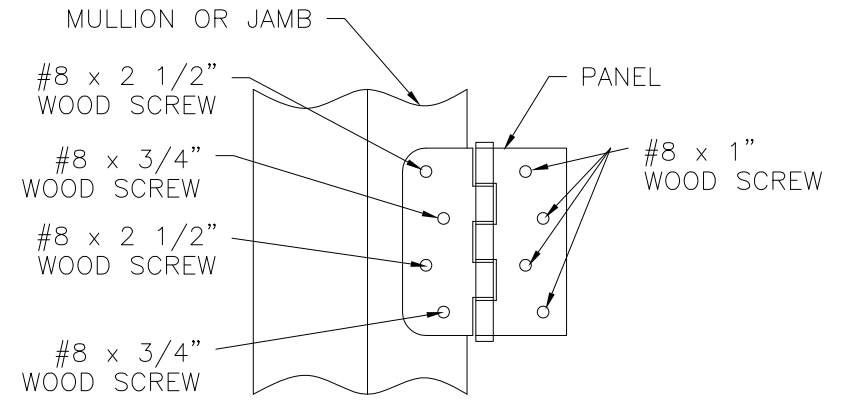
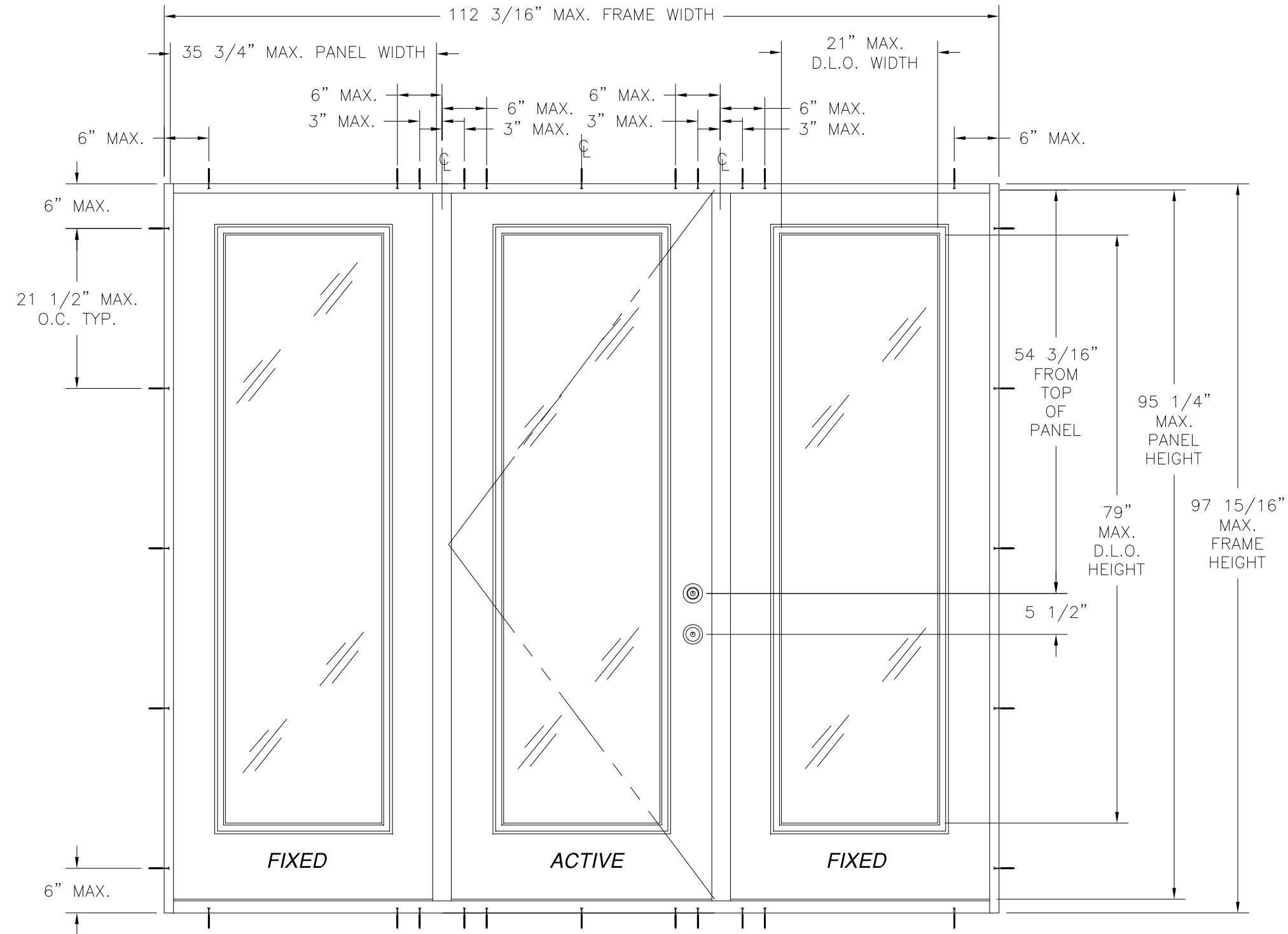

TOP HINGE DETAIL
MULLION OR
2X BUCK/WOOD FRAMING INSTALLATION
6'8 AND 8'0 UNITS

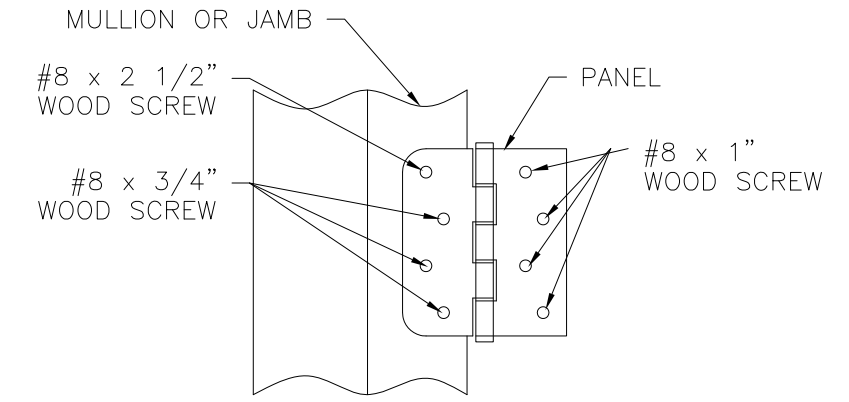

MIDDLE AND BOTTOM HINGE DETAIL
MULLION OR
2X BUCK/WOOD FRAMING INSTALLATION
6'8 AND 8'0 UNITS

PLASTPRO INSERT GLAZED FIBERGLASS 8'0 IS OXO DOOR
EXTERIOR VIEW

WHERE WATER IS REQUIRED	
DESIGN PRESSURE RATING	IMPACT RATING
+35.0 PSF -45.0 PSF	NONE

WHERE WATER IS NOT REQUIRED	
DESIGN PRESSURE RATING	IMPACT RATING
+40.0 PSF -45.0 PSF	NONE

APPROVED CONFIGURATIONS: O, X, OX, XO, OXO
ANCHORING LAYOUT ABOVE APPLIES TO ALL APPROVED CONFIGURATIONS.

WINCORE WINDOW COMPANY, LLC.
250 STAUNTON AVE.
PARKERSBURG, WV 26102

PLASTPRO INSERT GLAZED FIBERGLASS IS/OS
OXO DOOR – NON-IMPACT
8'0 IS ELEVATION, ANCHORING LAYOUT AND HINGES

DRAWN: TJH	DWG NO. 08-01102	REV A
SCALE NTS	DATE 09/03/10	SHEET 3 OF 9

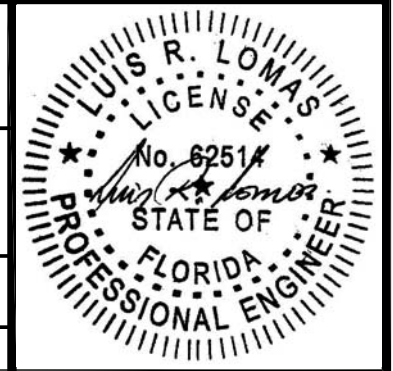

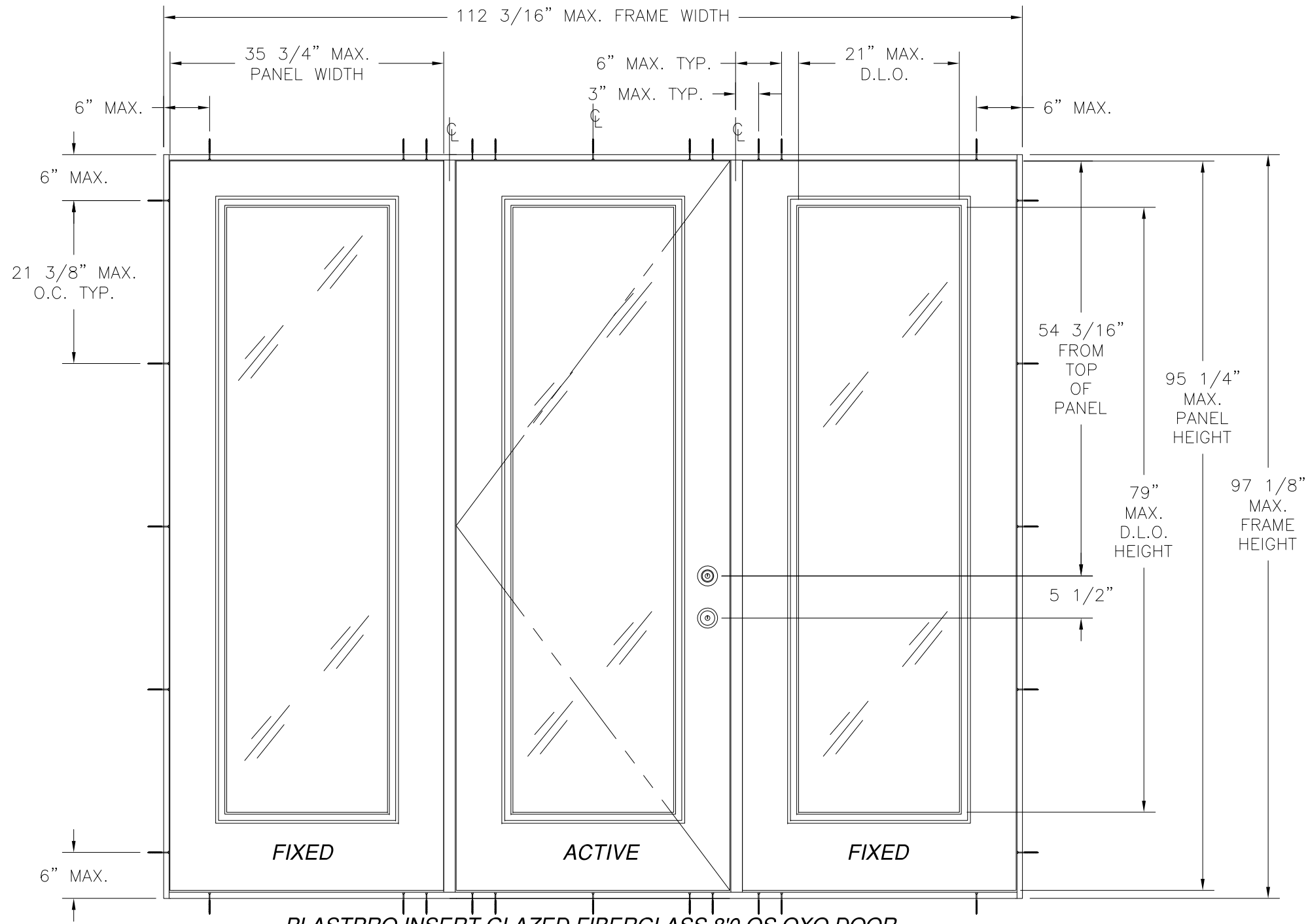

REVISIONS			
REV	DESCRIPTION	DATE	APPROVED
A	ADDED FRAME MATERIAL	2/28/11	R.L.

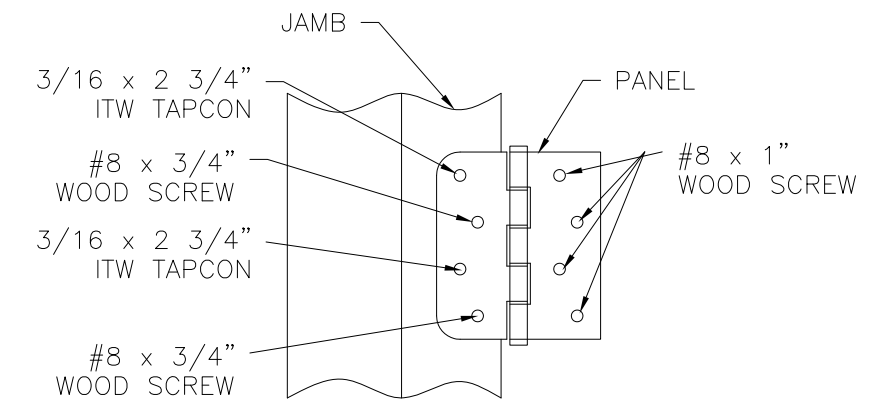

TOP HINGE DETAIL
MASONRY/CONCRETE INSTALLATION
6'8 AND 8'0 UNITS

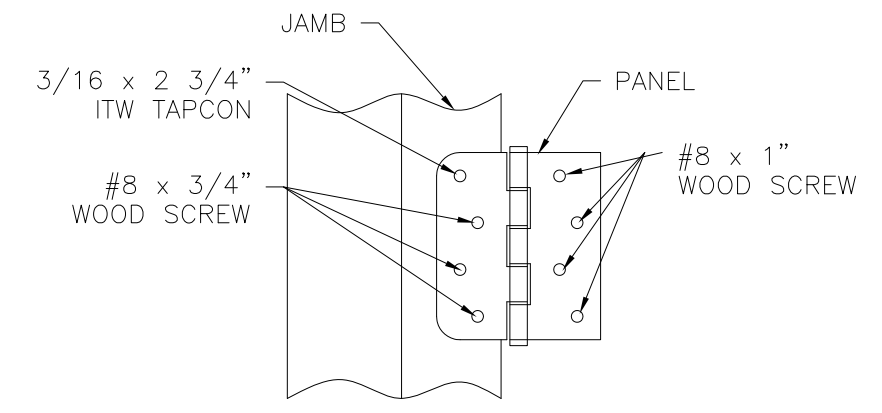

MIDDLE AND BOTTOM HINGE DETAIL
MASONRY/CONCRETE INSTALLATION
6'8 AND 8'0 UNITS

PLASTPRO INSERT GLAZED FIBERGLASS 8'0 OS OXO DOOR
EXTERIOR VIEW

WHERE WATER IS REQUIRED

DESIGN PRESSURE RATING	IMPACT RATING
+35.0 PSF -45.0 PSF	NONE

WHERE WATER IS REQUIRED W/ COMPOSITE FRAME

DESIGN PRESSURE RATING	IMPACT RATING
+35.0 PSF -40.0 PSF	NONE

WHERE WATER IS NOT REQUIRED

DESIGN PRESSURE RATING	IMPACT RATING
+40.0 PSF -45.0 PSF	NONE

WHERE WATER IS NOT REQUIRED W/ COMPOSITE FRAME

DESIGN PRESSURE RATING	IMPACT RATING
±40PSF	NONE

APPROVED CONFIGURATIONS: O, X, OX, XO, OXO
ANCHORING LAYOUT ABOVE APPLIES TO ALL APPROVED CONFIGURATIONS.

WINCORE WINDOW COMPANY, LLC.
250 STAUNTON AVE.
PARKERSBURG, WV 26102

PLASTPRO INSERT GLAZED FIBERGLASS IS/OS
OXO DOOR – NON-IMPACT
8'0 OS ELEVATION, ANCHORING LAYOUT AND HINGES

DRAWN: TJH	DWG NO. 08-01102	REV A
SCALE NTS	DATE 09/03/10	SHEET 4 OF 9

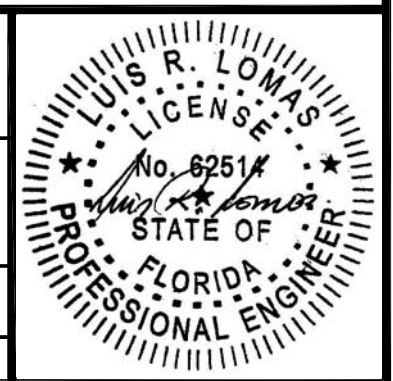

REVISIONS			
REV	DESCRIPTION	DATE	APPROVED
A	ADDED FRAME MATERIAL	2/28/11	R.L.

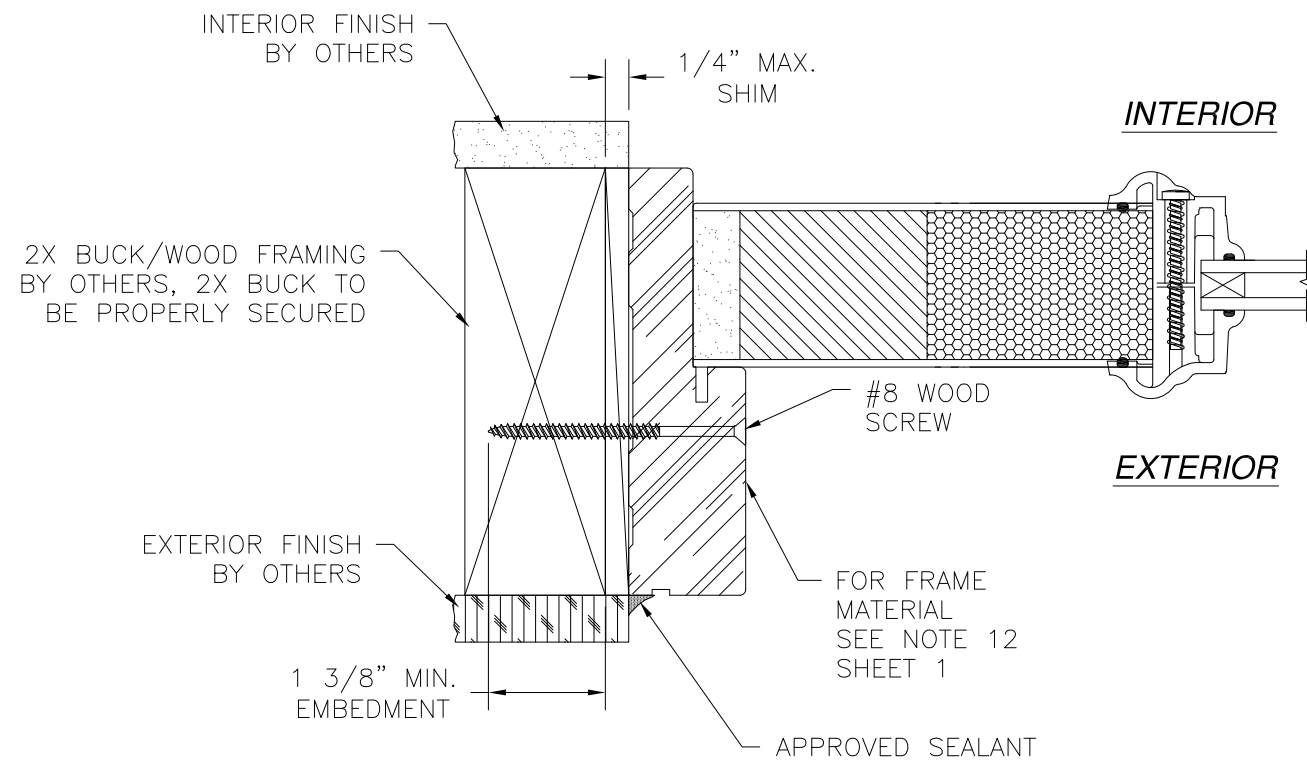
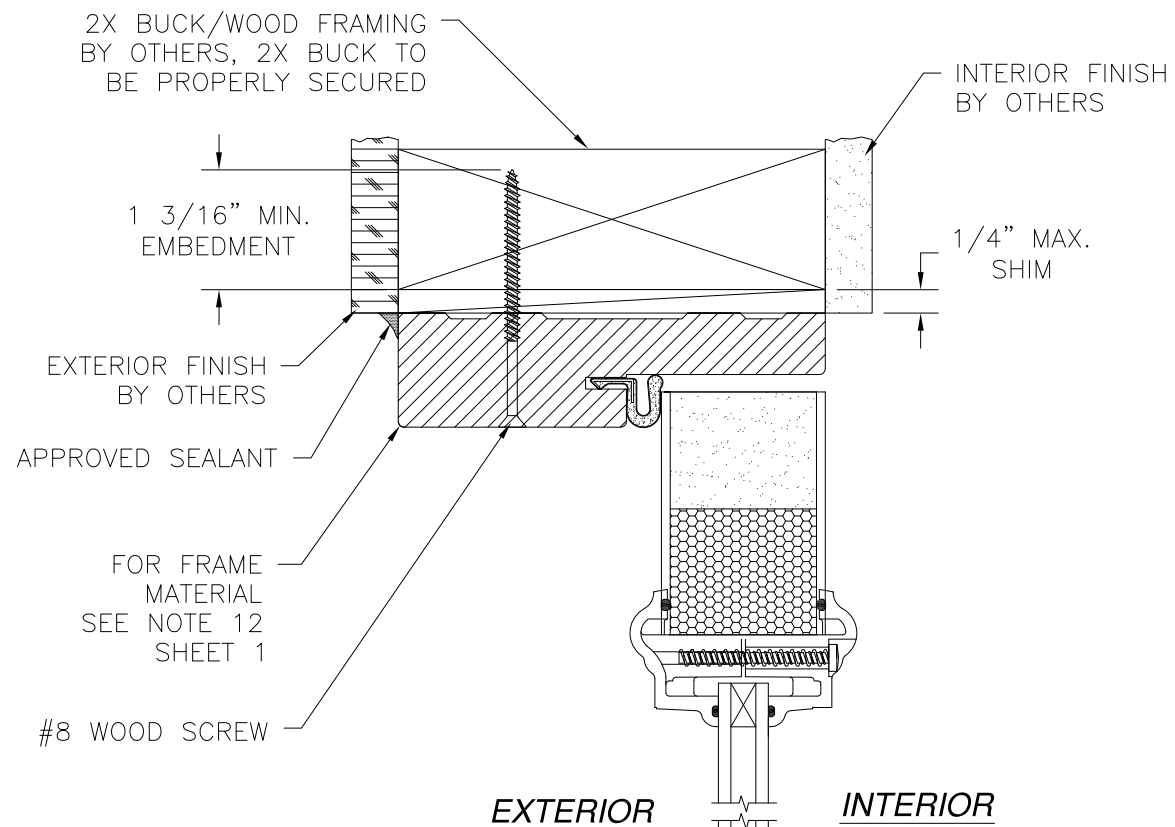

HORIZONTAL CROSS SECTION
 2X BUCK/WOOD FRAMING
 SIDELITE JAMB SHOWN, STRIKE
 AND HINGE JAMB SIMILAR

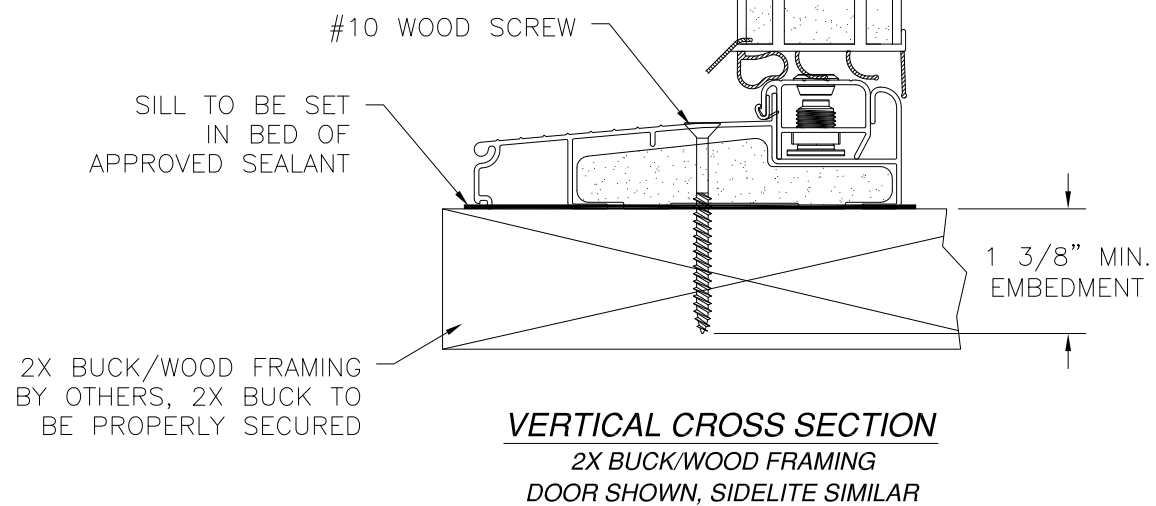

WINCORE WINDOW COMPANY, LLC.
 250 STAUNTON AVE.
 PARKERSBURG, WV 26102

PLASTPRO INSERT GLAZED FIBERGLASS IS/OS
 OXO DOOR - NON-IMPACT
 INSWING INSTALLATION DETAILS

DRAWN: TJH	DWG NO. 08-01102	REV A
SCALE NTS	DATE 09/03/10	SHEET 5 OF 9



REVISIONS			
REV	DESCRIPTION	DATE	APPROVED
A	ADDED FRAME MATERIAL	2/28/11	R.L.

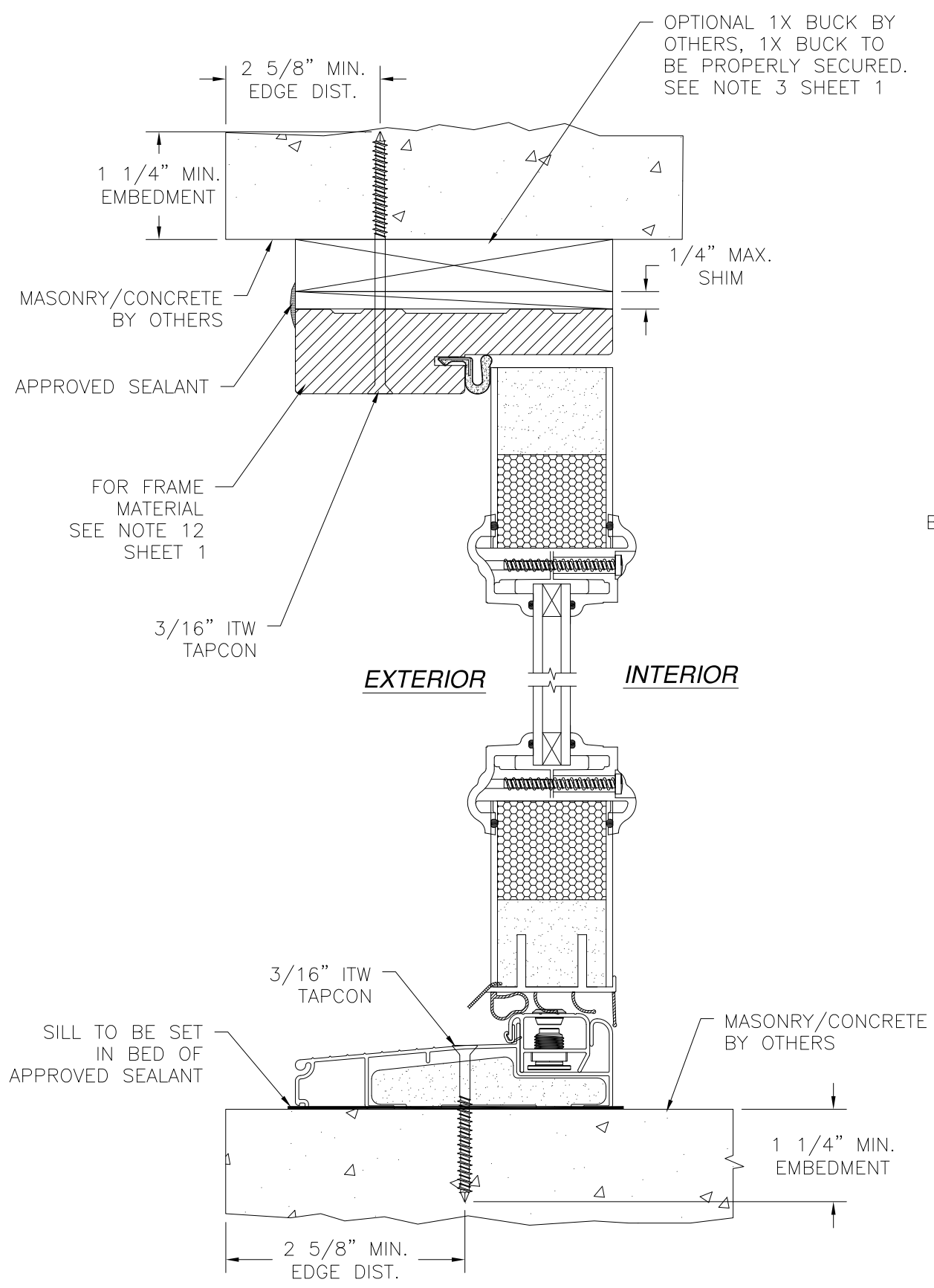

VERTICAL CROSS SECTION
MASONRY/CONCRETE INSTALLATION
DOOR SHOWN, SIDELITE SIMILAR

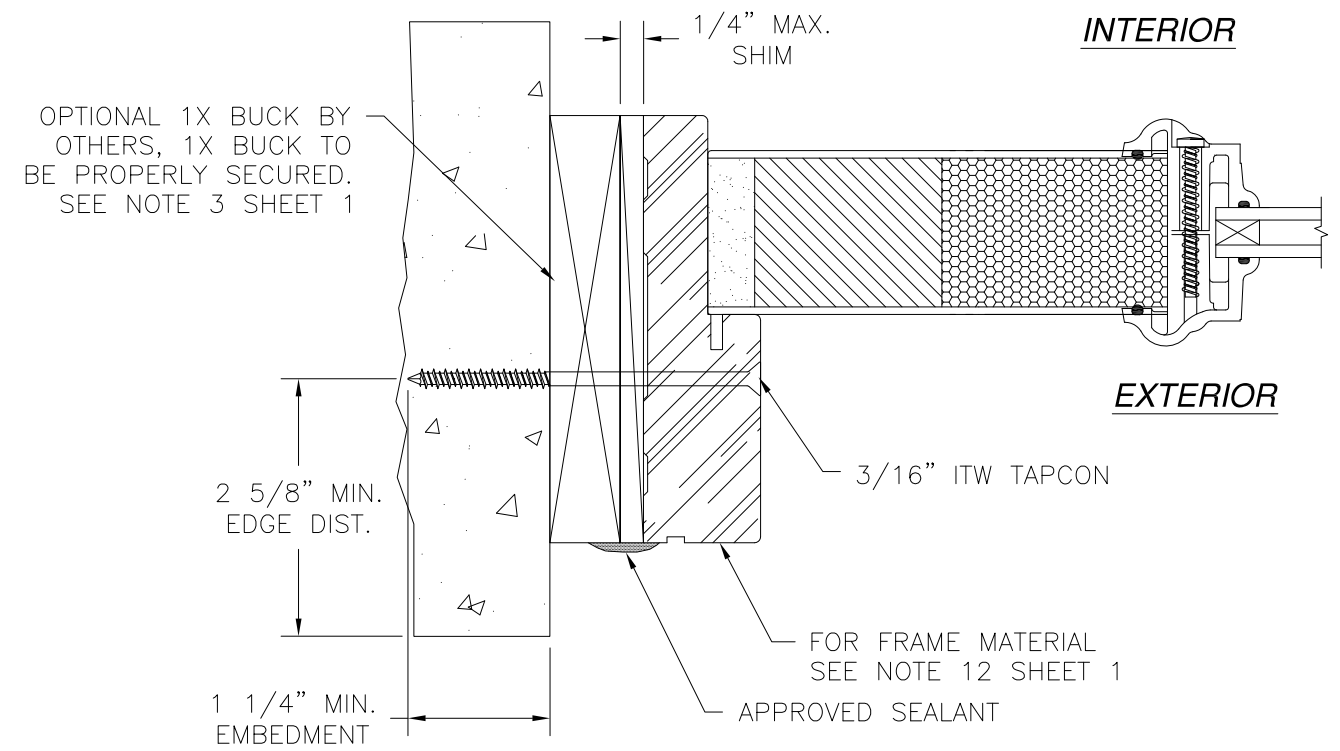

HORIZONTAL CROSS SECTION
MASONRY/CONCRETE INSTALLATION
SIDELITE JAMB SHOWN, STRIKE
AND HINGE JAMB SIMILAR

WINCORE WINDOW COMPANY, LLC.
250 STAUNTON AVE.
PARKERSBURG, WV 26102

PLASTPRO INSERT GLAZED FIBERGLASS IS/OS
OXO DOOR – NON-IMPACT
INSWING INSTALLATION DETAILS

DRAWN: TJH	DWG NO. 08-01102	REV A
SCALE NTS	DATE 09/03/10	SHEET 6 OF 9

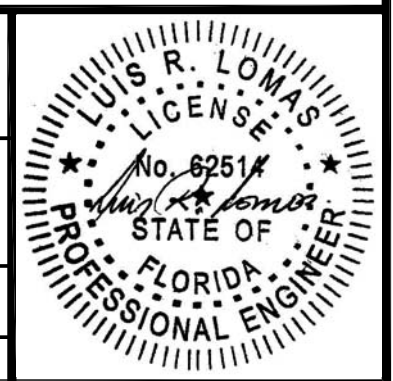

REVISIONS			
REV	DESCRIPTION	DATE	APPROVED
A	ADDED FRAME MATERIAL	2/28/11	R.L.

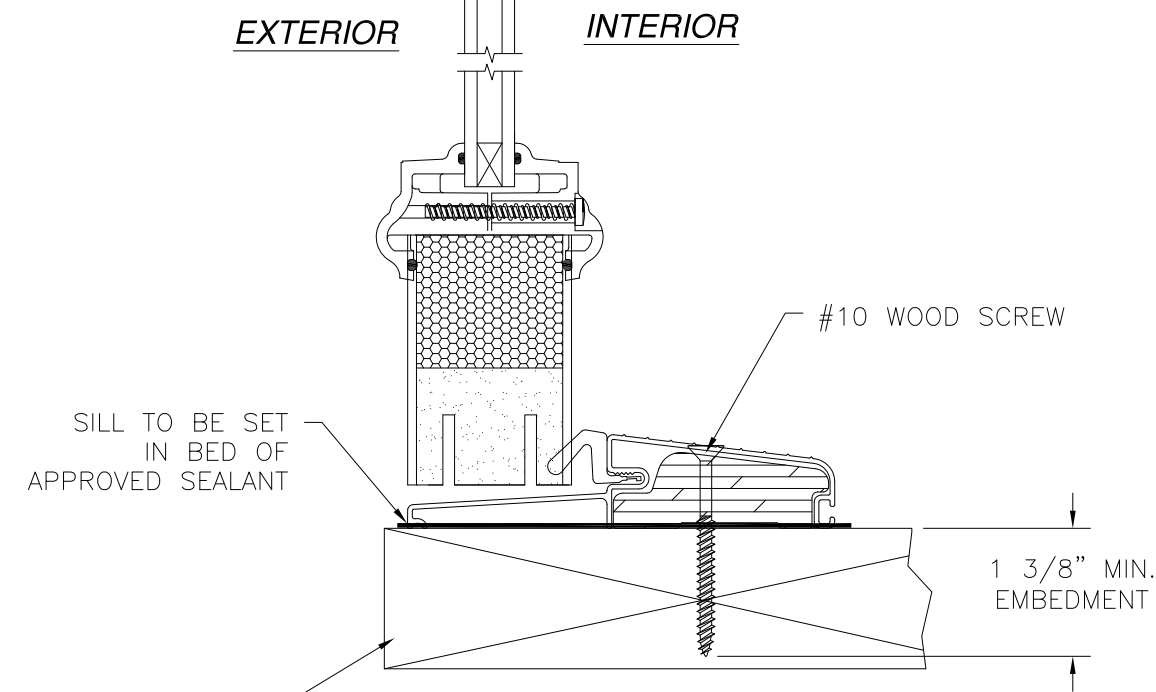
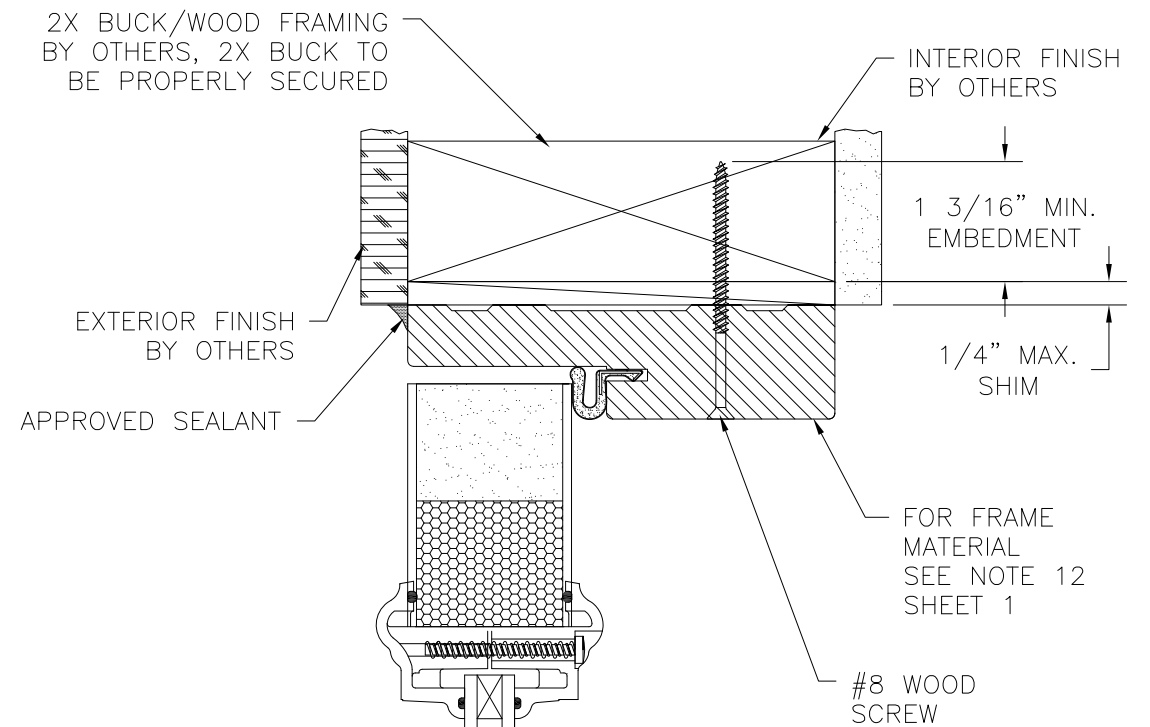

VERTICAL CROSS SECTION
2X BUCK/WOOD FRAMING
DOOR SHOW, SIDELITE SIMILAR

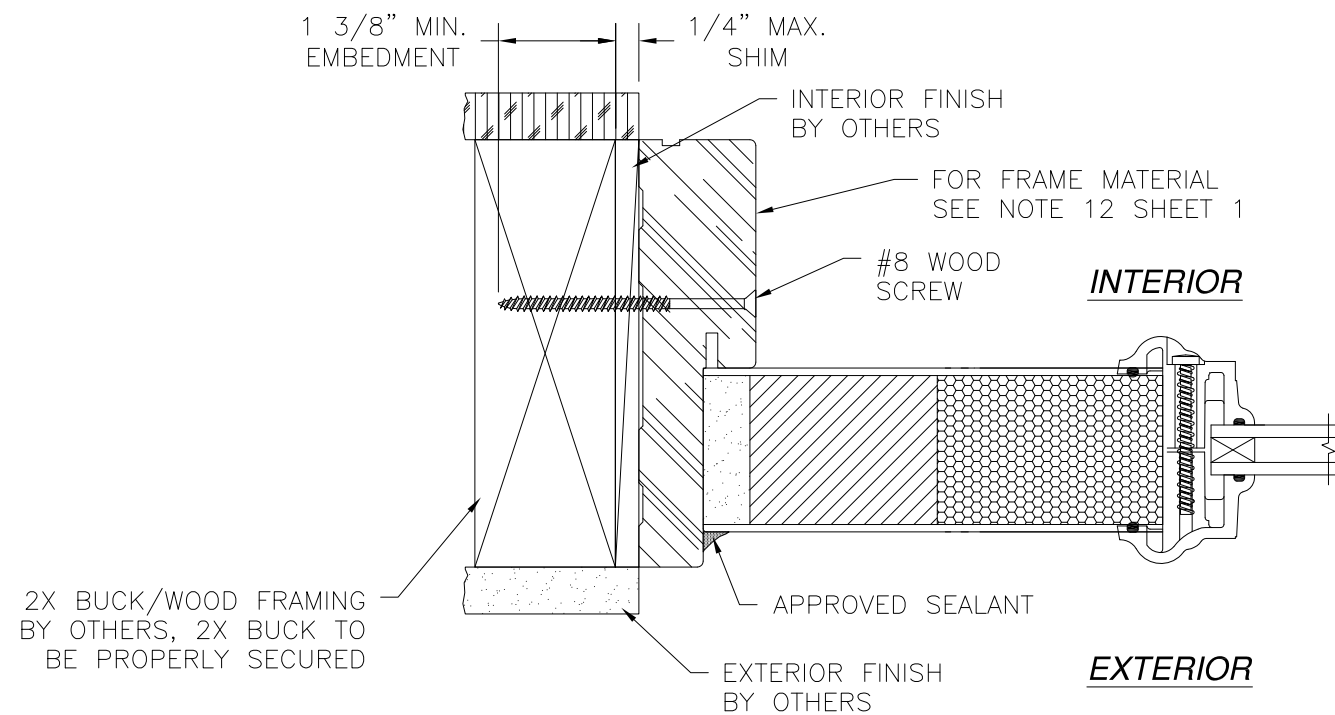

HORIZONTAL CROSS SECTION
2X BUCK/WOOD FRAMING
SIDELITE JAMB SHOWN, STRIKE
AND HINGE JAMB SIMILAR

WINCORE WINDOW COMPANY, LLC.
250 STAUNTON AVE.
PARKERSBURG, WV 26102

PLASTPRO INSERT GLAZED FIBERGLASS IS/OS
OXO DOOR - NON-IMPACT
OUTSWING INSTALLATION DETAILS

DRAWN: TJH	DWG NO. 08-01102	REV A
SCALE NTS	DATE 09/03/10	SHEET 7 OF 9

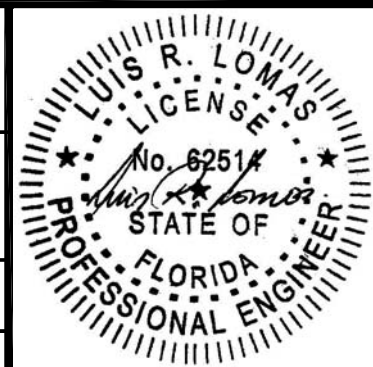

REVISIONS			
REV	DESCRIPTION	DATE	APPROVED
A	ADDED FRAME MATERIAL	2/28/11	R.L.

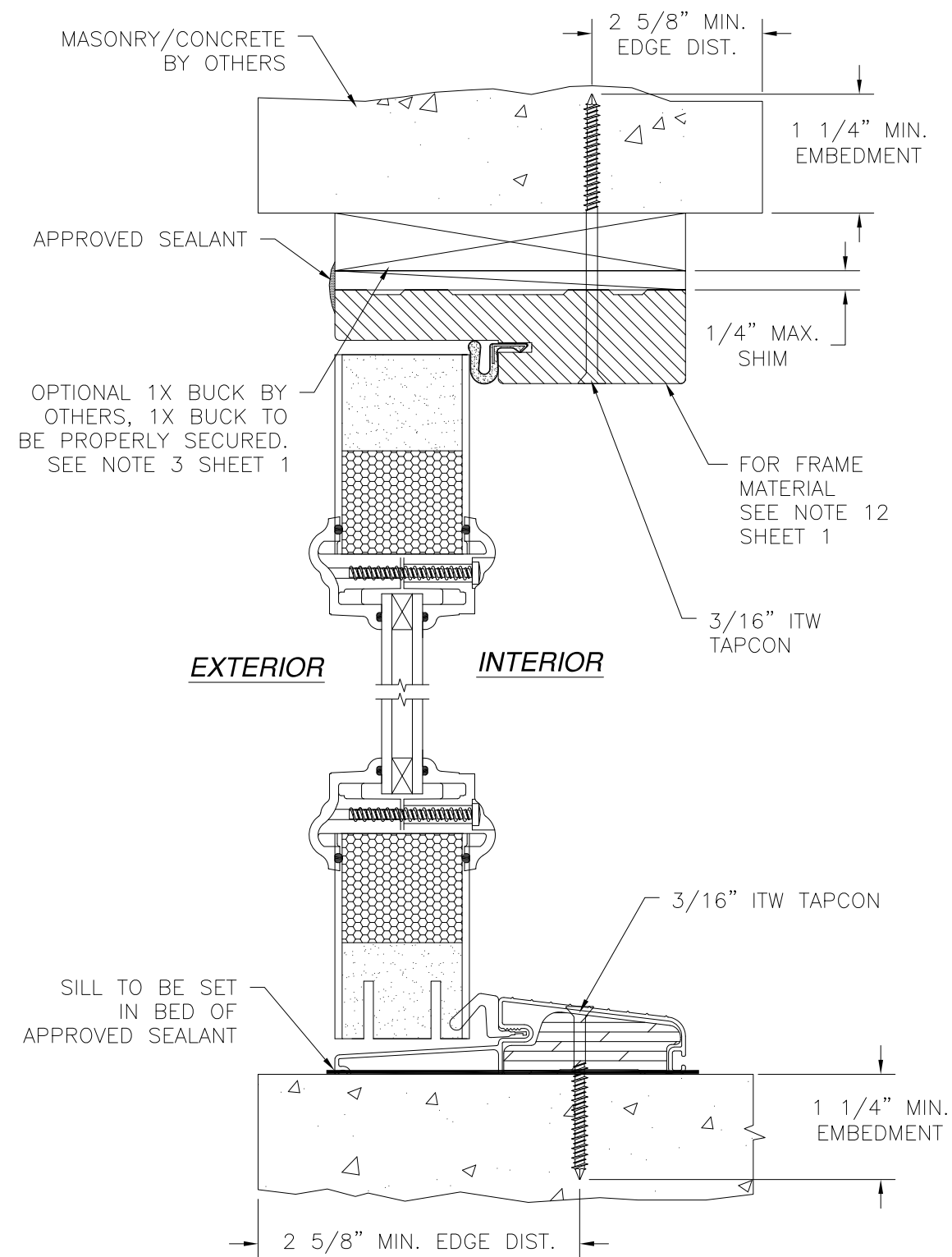

VERTICAL CROSS SECTION
 2X BUCK/WOOD FRAMING
 DOOR SHOWN, SIDELITE SIMILAR

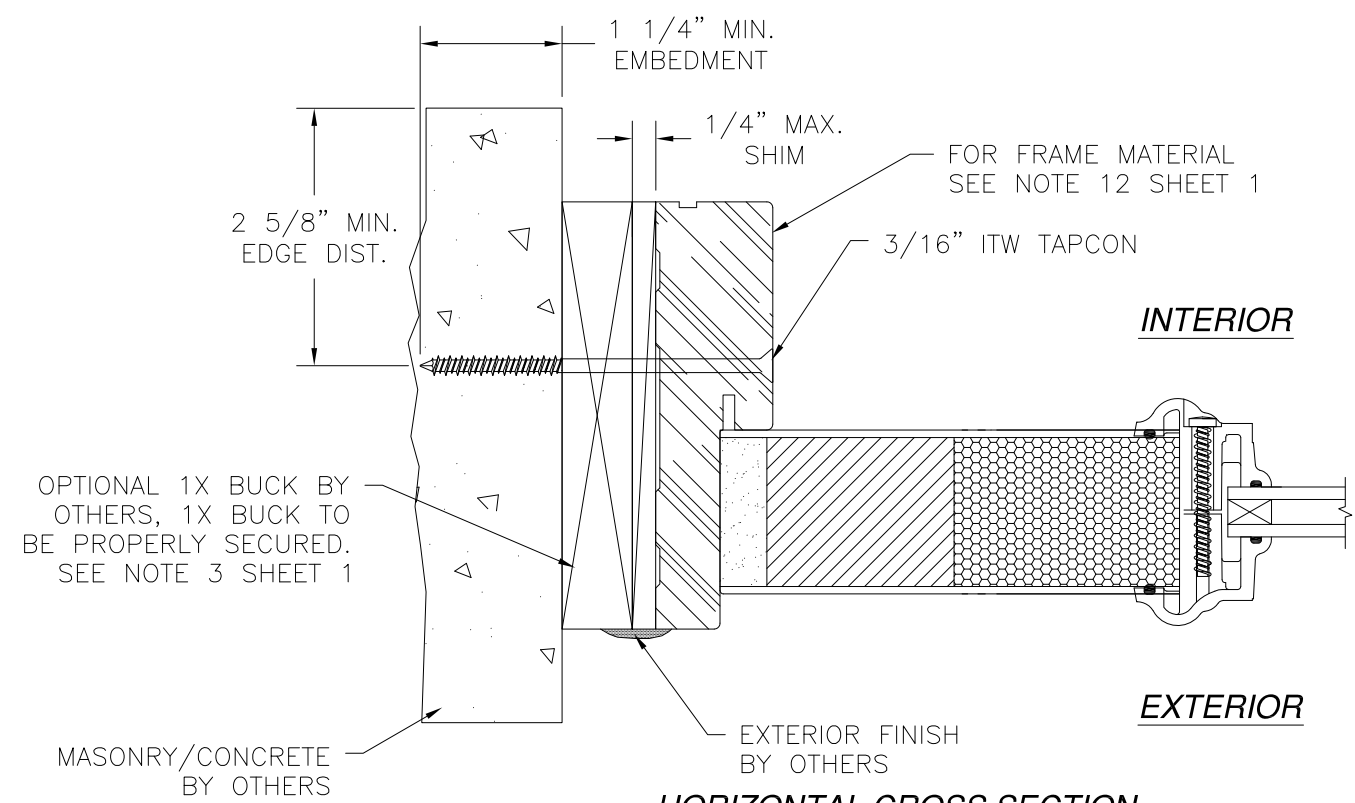

HORIZONTAL CROSS SECTION
 MASONRY/CONCRETE INSTALLATION
 SIDELITE JAMB SHOWN, STRIKE
 AND HINGE JAMB SIMILAR

WINCORE WINDOW COMPANY, LLC.
 250 STAUNTON AVE.
 PARKERSBURG, WV 26102

PLASTPRO INSERT GLAZED FIBERGLASS IS/OS
 OXO DOOR – NON-IMPACT
 OUTSWING INSTALLATION DETAILS

DRAWN: TJH	DWG NO. 08-01102	REV A
SCALE NTS	DATE 09/03/10	SHEET 8 OF 9

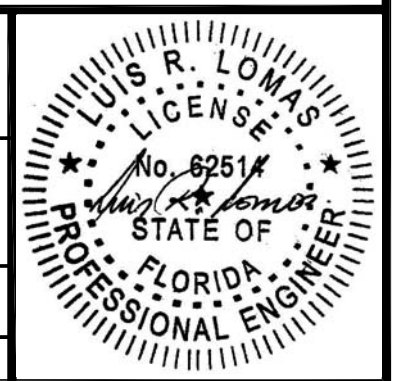

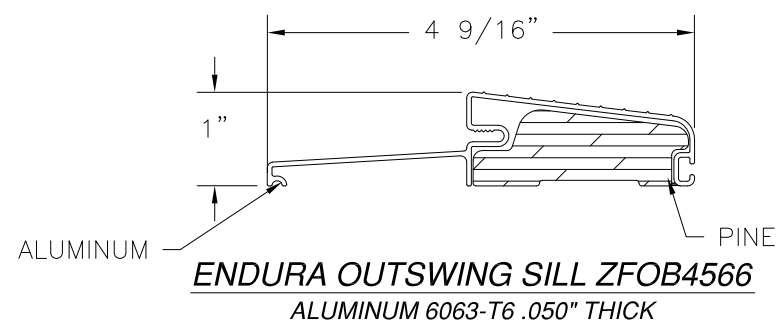
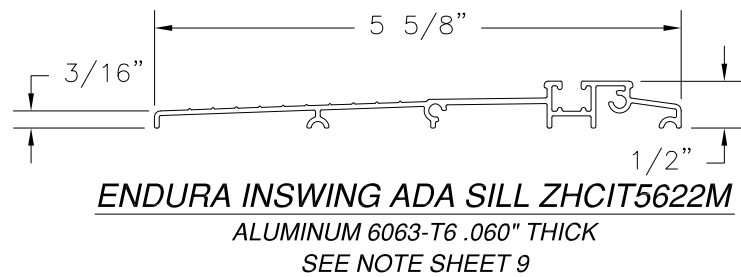
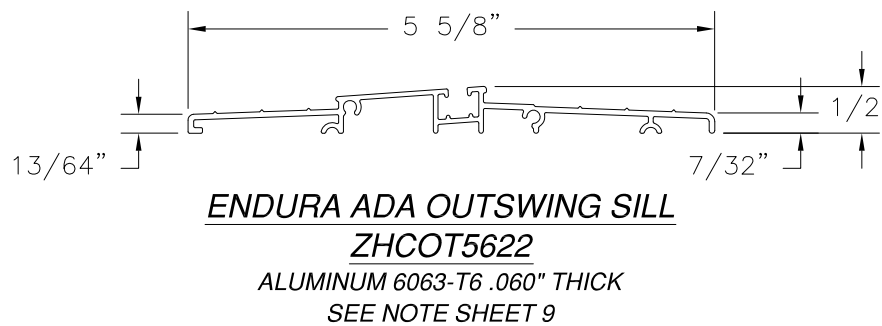
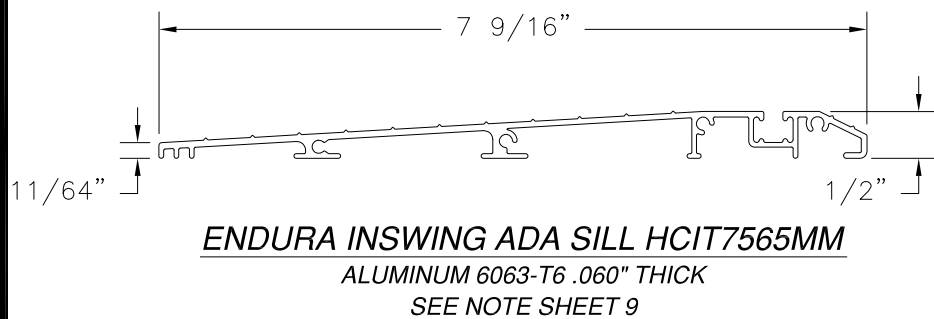
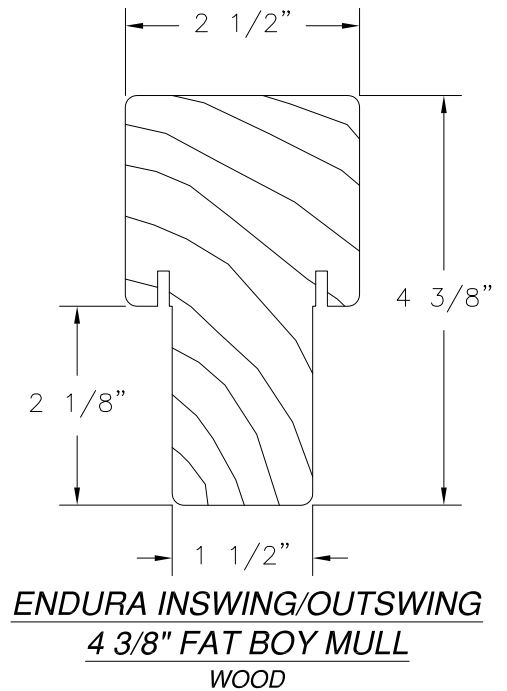
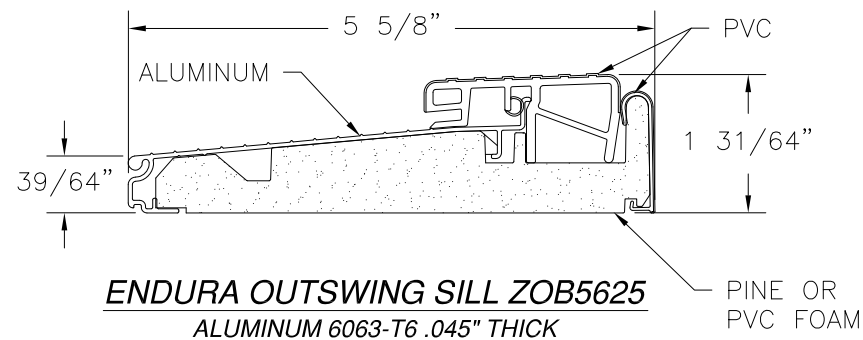
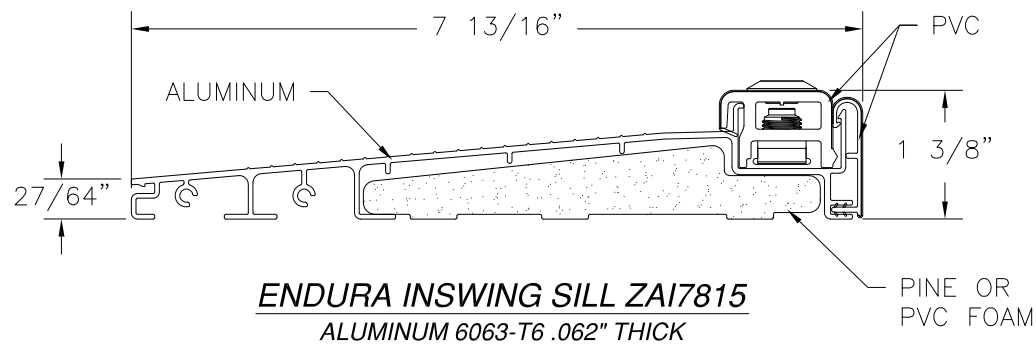
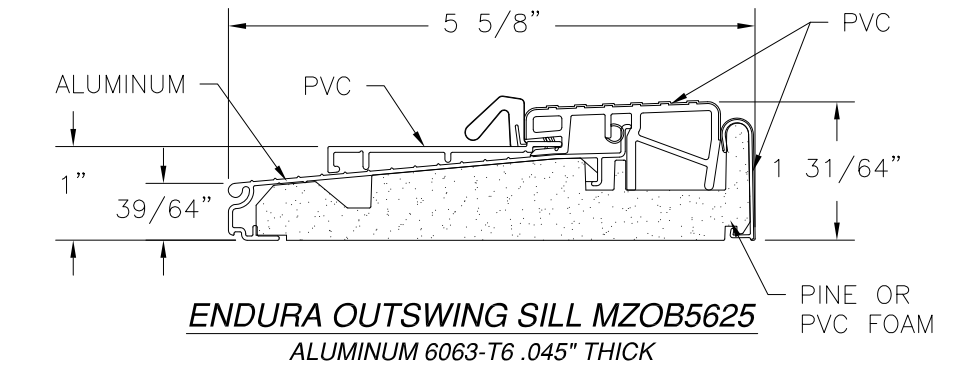
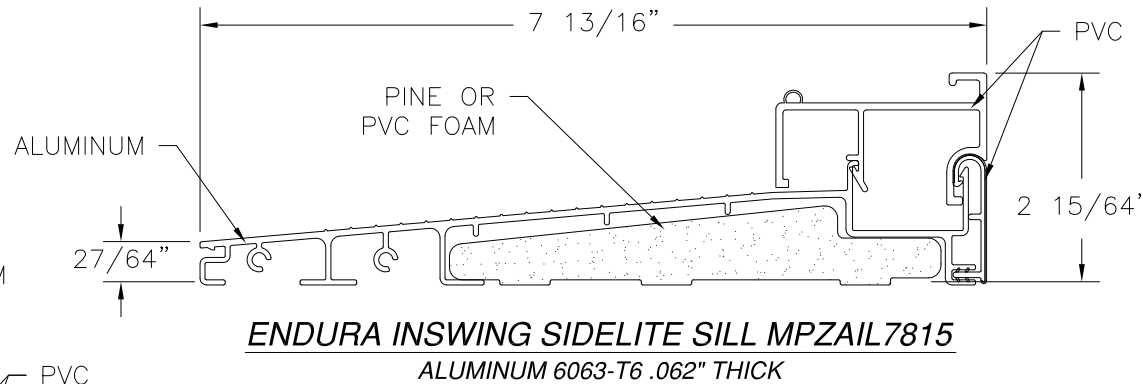
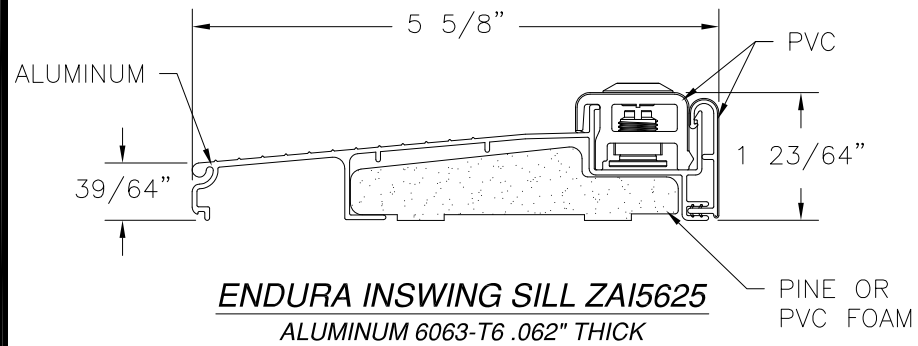
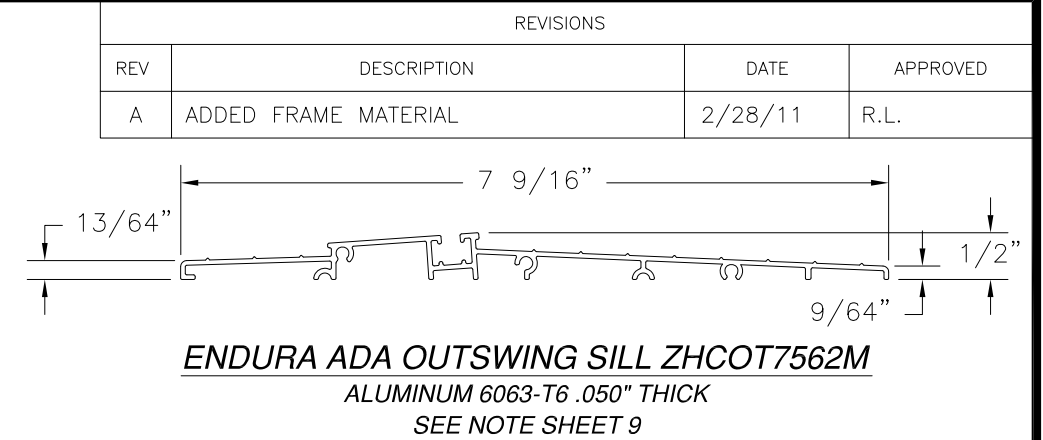
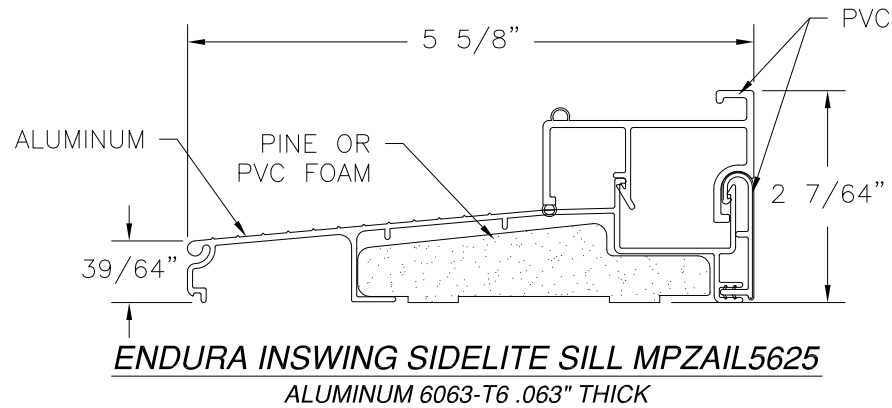
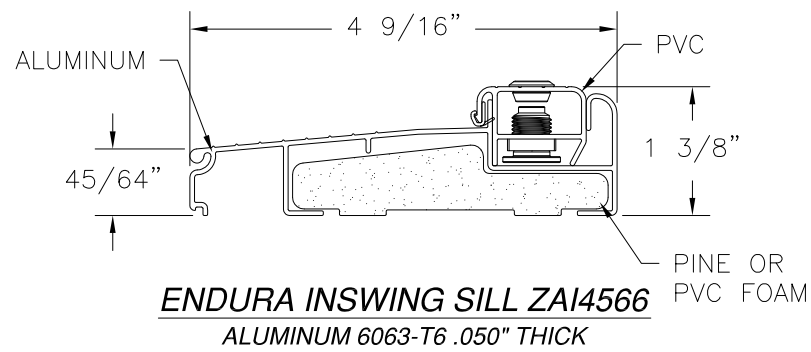

NOTE: ADA SILLS HAVE NOT BEEN TESTED FOR WATER RESISTANCE AND MUST ONLY BE INSTALLED IN AREAS WHERE WATER RESISTANCE IS NOT REQUIRED.

WINCORE WINDOW COMPANY, LLC.
250 STAUNTON AVE.
PARKERSBURG, WV 26102

PLASTPRO INSERT GLAZED FIBERGLASS IS/OS
OXO DOOR - NON-IMPACT
APPROVED SILLS AND MULL DETAIL

DRAWN: TJH	DWG NO. 08-01102	REV A
SCALE NTS	DATE 09/03/10	SHEET 9 OF 9

